



Product Name	GAOTek GPS Smart Return FPV Drone
Product SKU	GAOTek-FPV-103
Product URL	https://gaotek.com/product/gaotek-gps-smart-return-fpv-drone/

Contact us: sales@gaotek.com

Page 1 of 12

Based in New York City & Toronto, GAO Tek Inc. is ranked as one of the top 10 global B2B technology suppliers. GAO ships overnight within the U.S. & Canada & provides top-notch support thanks to its 4 decades of experience.



Contents

1. Product Overview:	3
2. Pre-Flight Preparation:	4
2.1: App Installation:	4
2.3: Aircraft Installation Battery:	4
2.4: Smart Battery Charging:	5
2.5: Remote Control Charging:	5
2.6: Expand The Remote Control and Place the Mobile Phone:	5
2.7: Remote Control Frequency Matching:	6
2.8: Gyro Calibration:	6
3. Start First Flight:	7
3.1: Compass Calibration:	7
3.2 Description of Flight Mode Status:	7
3.3 Motor Unlocking / Locking:	8
3.4 Basic Flight Steps:	8
3.5 One-Click Unlocking (Remote Control Operation):	9
3.6 One-Touch Landing (Remote Control Operation):	9
3.7 visual positioning mode (remote control operation):	10
3.8 Outdoor GPS Mode (Remote Control Operation):	10
3.9 Automatic Return Mode:	10
3.10 Intelligent Low Voltage Return:	11
3.11 Fence Mode:	11
3.12 Headless Mode:	12



GAOTek GPS Smart Return FPV Drone

1. Product Overview:

- New modular design concept, easy to install, maintain, update and upgrade, etc.
- Equipped with 5g WIFI digital image transmission system, it brings you different visual effects
- Built in the latest generation of flight control system to provide stable and reliable flight performance
- Built-in GPS positioning and navigation system makes flight more accurate and safer
- Integrated design, plug-in installation, simple and convenient

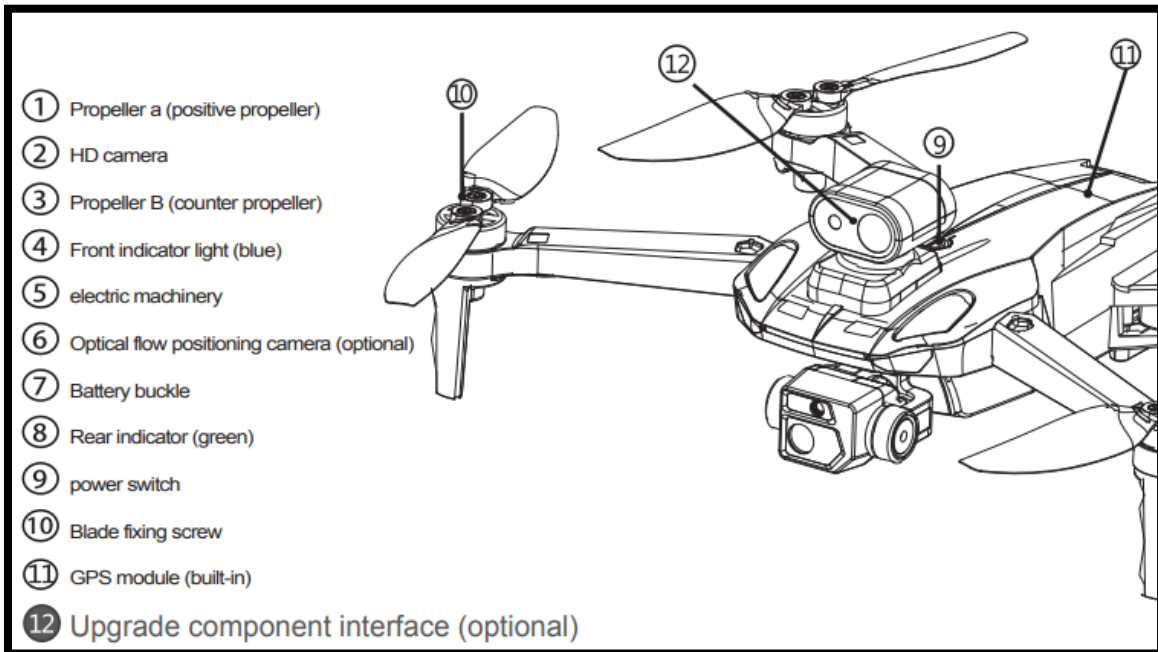
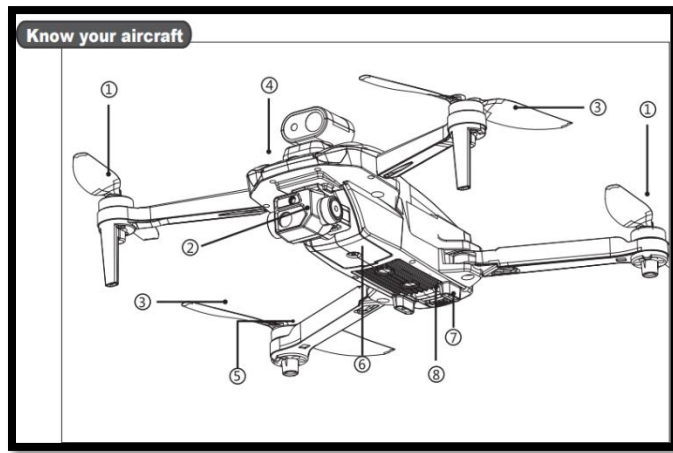



2. Pre-Flight Preparation:

2.1: App Installation:

Please use your mobile device to scan the QR code for download when installing the app. For scanning the QR code and instructions, please refer to the detailed page of APP operation instructions.

2.2: Deployment Arm:

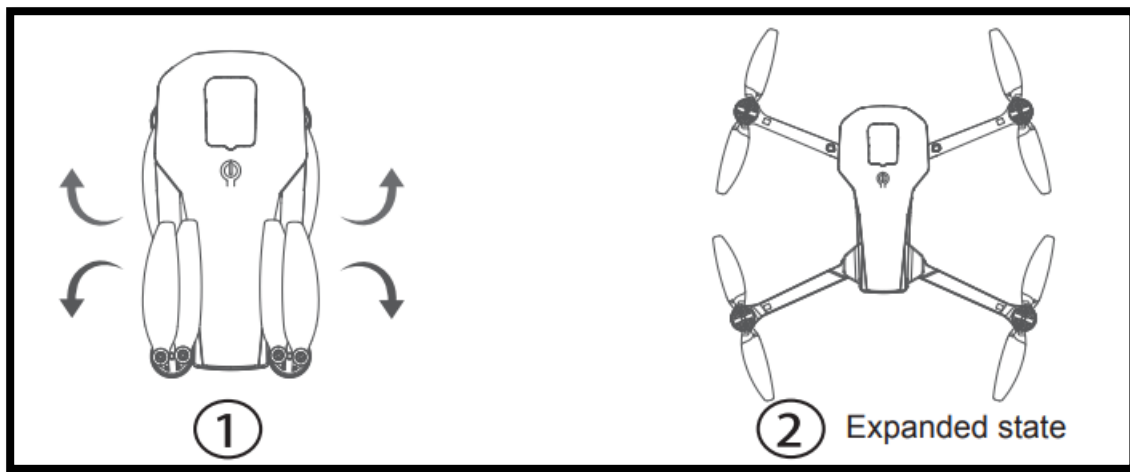

2.3: Aircraft Installation Battery:

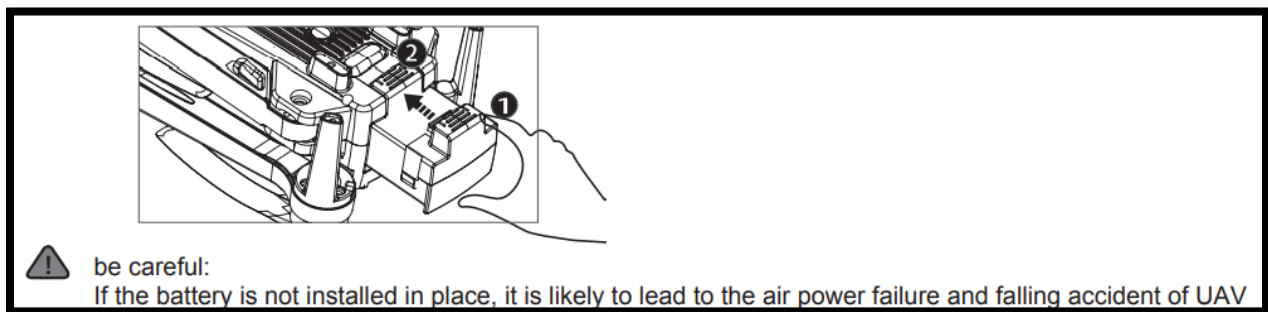



2.4: Smart Battery Charging:

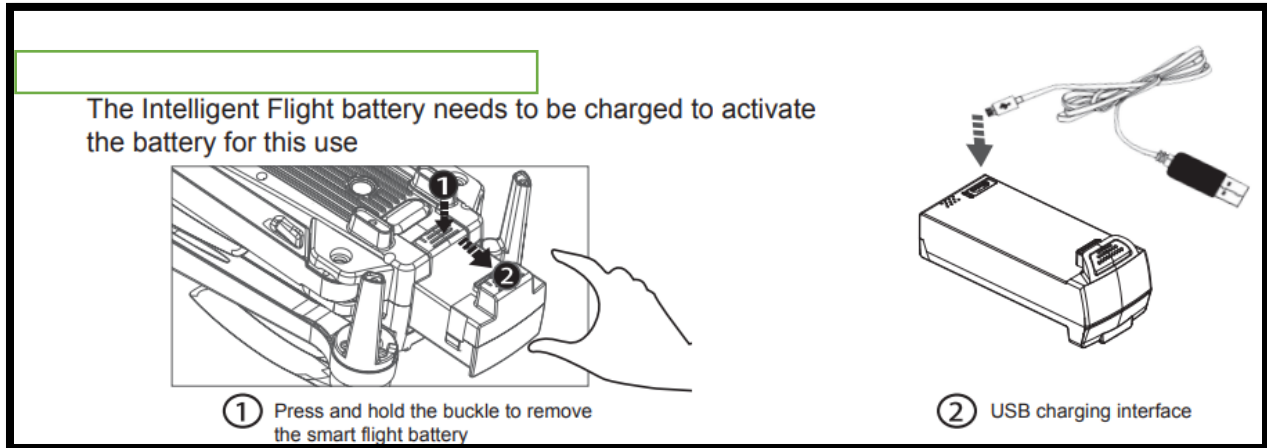

2.5: Remote Control Charging:

- The remote control has a built-in rechargeable battery. When the remote control is low, the low-voltage prompt light will
- flash slowly, and the remote control will make a drip sound to prompt that it needs to be charged;
- Connect the 5V USB data cable to charge the battery. The charging time is about 50 minutes.
- The green light of the remote controller is always on during charging, and the green light goes out after charging

2.6: Expand The Remote Control and Place the Mobile Phone:

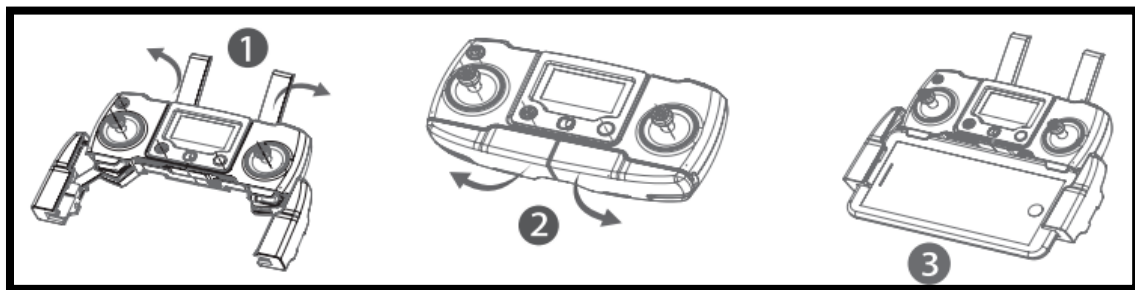



- In the remote-control storage state, the first step is to expand the antenna to ensure that the antenna is vertical, and then rotate the handle.
- Open the handle, put in the mobile connecting equipment, and adjust the position to ensure the stable placement of the equipment

2.7: Remote Control Frequency Matching:

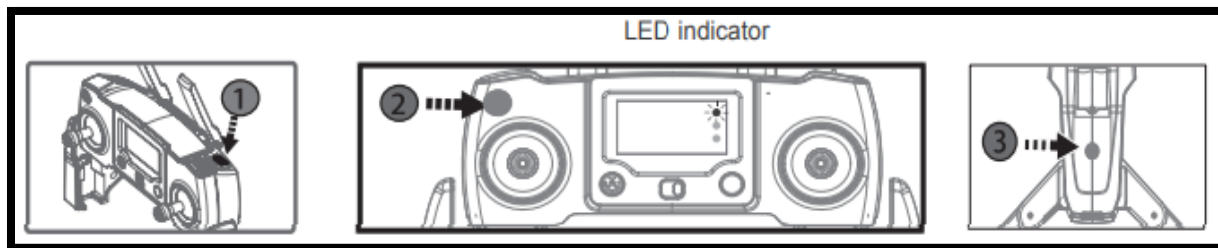

- When the remote control is turned off, press and hold the photographing button for a long time (as shown in Figure 1)
- At the same time, turn on the remote control. At this time, the remote control makes a "drip" sound, and the LED flashes;
- When the aircraft is powered on, the remote controller emits "didi" twice, and the LED light stops flashing, indicating that
- the frequency alignment is successful; After successful frequency alignment, the aircraft can be directly controlled, If the frequency alignment is unsuccessful, please repeat the above steps

2.8: Gyro Calibration:

After successful code alignment, place the aircraft on the horizontal ground and push the left and right rocker rods to the lower right at the same time according to the instructions in the figure below. At this time, the front and rear indicator lights flash rapidly, and the gyroscope enters the calibration state. When the indicator light changes from flash to constant light, the calibration is completed.

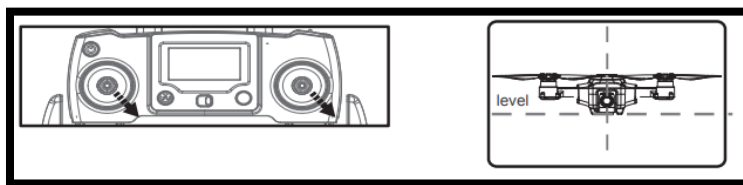



3. Start First Flight:

3.1: Compass Calibration:

- When the user starts up for use for the first time, the compass needs to be calibrated. If there is no abnormality in later use, the compass does not need to be calibrated again;
- If there is a circle or abnormal deviation in flight, please recalibrate the compass
- Please calibrate the compass in an outdoor open area and stay away from electromagnetic fields
τ Disturbance environment calibration compass
- Turn the remote control to the direction shown in Figure 1 at the same time, and keep it still until the blue light in front of the aircraft is always on, and the remote control makes a "drip" sound;
- Slowly rotate the aircraft horizontally for several turns until the green indicator at the back of the aircraft is always on, the blue indicator at the front is off, and the remote control beeps;
- Rotate the aircraft nose up slowly for several turns until the front and rear indicators of the aircraft are on, and the remote control emits a "drip" sound again, indicating that the indicator calibration is successful. If the calibration is unsuccessful, please repeat the above steps.

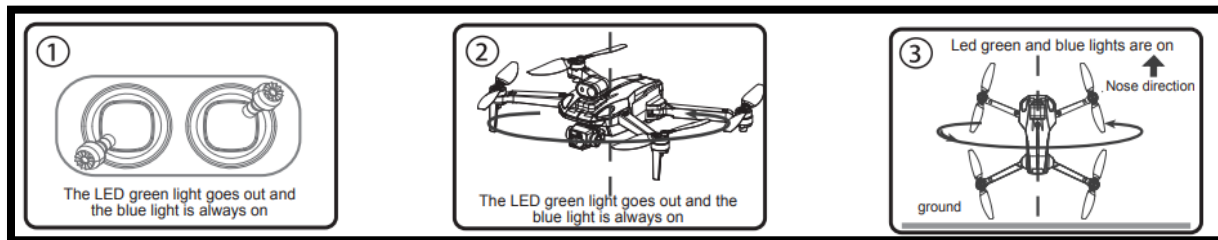

3.2 Description of Flight Mode Status:

- Visual positioning mode: turn the remote-control mode switch to the left visual positioning mode, and the blue and green lights at the front and rear of the aircraft are always on.
- Outdoor GPS mode: turn the remote-control mode switch to the outdoor GPS visual positioning mode on the right, and the blue and green lights in the front and rear of the aircraft flash, indicating that no satellites have been searched or the number of search satellites is not enough. The number of GPS satellites reaches more than 8, and the front blue light is always on, indicating that the GPS satellite
- search and positioning are successful.



- Headless mode: the aircraft moves forward and backward from the takeoff position to the arrow direction of the aircraft, and the vertical direction of the arrow is left and right.
- Automatic return mode: during flight, press the automatic return key to switch to the automatic return mode. The green light flashes slowly, indicating that the aircraft enters the return mode.
- When the aircraft has low power, the blue-green indicator flashes quickly, indicating that the aircraft has low power and the operator needs to fly carefully within the line of sight.
- Comparison table of mode status and flight indicator

Mode status	Flight signal indicator (blue)	Flight status backlight (green)
Visual positioning mode	constant	Chang Liang
Outdoor GP mode (positioning)	Chang Liang	twinkle
Outdoor GPS mode (not located)	twinkle	twinkle
Headless mode	Flash 3 times	Flash 3 times
Automatic return mode	Chang Liang	twinkle
Primary low voltage	Slow flash	Slow flash
Secondary low voltage	flash	flash
Remote control not connected	flash	flash
Insufficient flight conditions	Alternating slow flash	Alternating slow flash

3.3 Motor Unlocking / Locking:

Method 1: After successful code alignment, turn the switch to the visual positioning mode or outdoor GPS mode. As shown in the right figure, pull the left and right rocker and keep it still until the indicator light flashes twice. After unlocking, the motor will rotate at a low speed.

Method 2: Long press the one key unlock button to unlock.

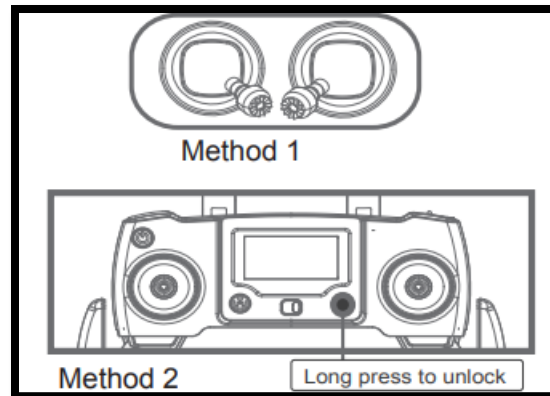

3.4 Basic Flight Steps:

1. Place the aircraft on a flat and open ground with the user-facing the tail.
2. Turn on the remote control and aircraft
3. The remote controller and the aircraft are matched, and the aircraft is initialized.



4. Run the app, connect the mobile device, and enter the camera interface
5. After the aircraft gyroscope is detected, unlock the aircraft
6. Slowly push the accelerator upward to make the aircraft take off smoothly
7. Pull down the throttle lever to lower the aircraft
8. After landing, pull the accelerator to the lowest position and hold it for more than 3 seconds until the motor stops.
9. After shutdown, turn off the power supply of the aircraft and remote controller in turn.

3.5 One-Click Unlocking (Remote Control Operation):

Please unlock the motor in GPS mode before takeoff Make sure the signal is searched (the front blue LED is always on) The green light in the back flashes, indicating that the satellite search is completed and the GPS outdoor flight conditions are met



3.6 One-Touch Landing (Remote Control Operation):





3.7 visual positioning mode (remote control operation):

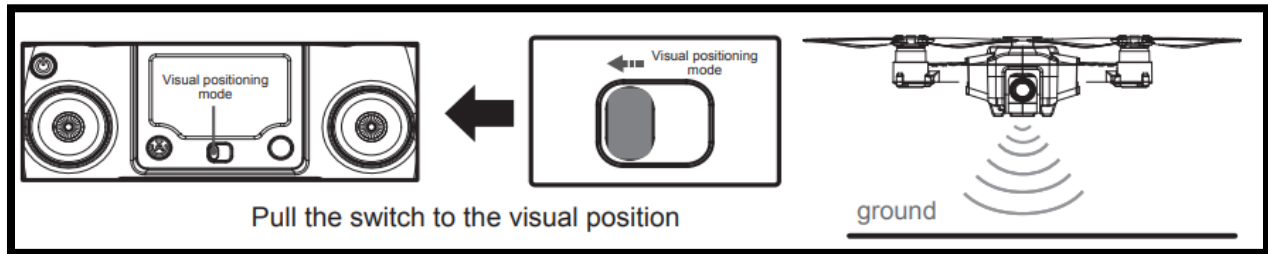

3.8 Outdoor GPS Mode (Remote Control Operation):

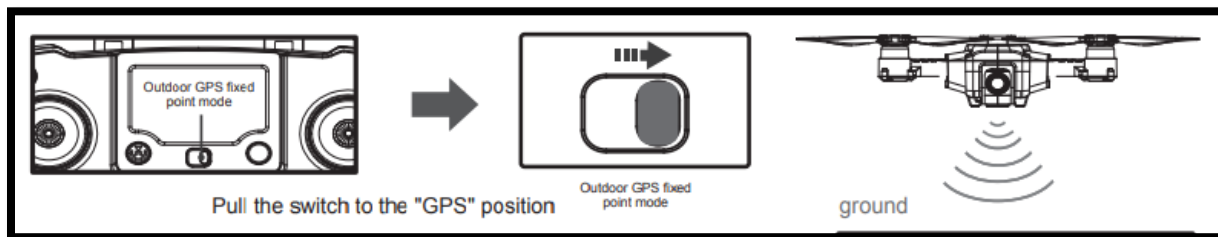

3.9 Automatic Return Mode:

- 1) Ensure that GPS positioning signals are received (more than 8 satellites);
- 2) Before starting the automatic return mode, please confirm that the flight altitude of the aircraft is higher than the obstacles on the return line;
- 3) There are no pedestrians and sundries near the take-off point, and the aircraft will automatically return to the take-off point.

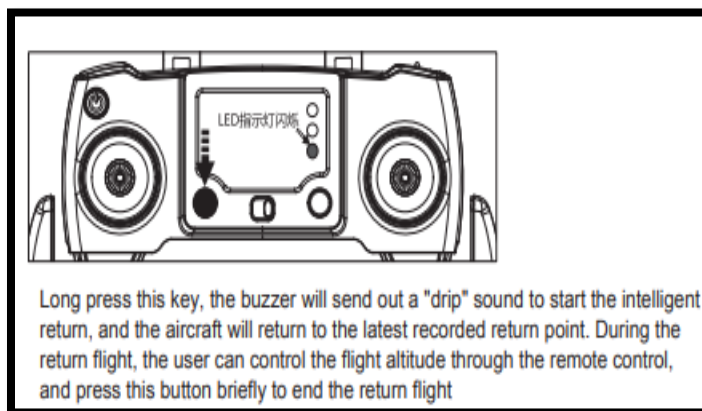



3.10 Intelligent Low Voltage Return:

- When the altitude of the aircraft is higher than 20m, the low-voltage return of the aircraft will maintain the existing altitude, automatically return above the Home point, and then land
- When the altitude of the aircraft is lower than 20m, the low-voltage return of the aircraft will climb to 20m high, auto

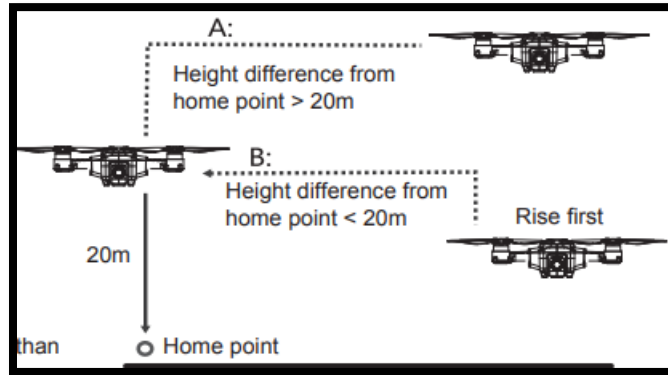

3.11 Fence Mode:

When starting up, the fence function is enabled by default. Press and hold the key on the left side of the remote control

for more than 2 seconds to turn off the fence function. Press and hold it again for 2 seconds to turn on the fence function.

Fence function: the flight height is limited to 30 meters and the flight distance is limited to 200 meters.

(The buzzer emits a long drip sound every time you switch.) matters needing attention

- 1) When novices practice flying, it is not recommended to cancel the fence functions
- 2) Do not fly in the no-fly area restricted by relevant laws and other regulations

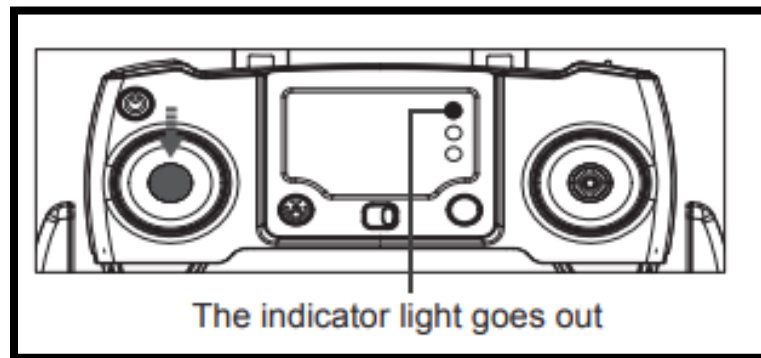



3.12 Headless Mode:

The indicator light is always on

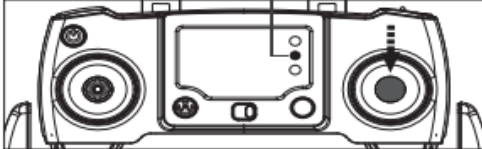

Long press this key on the remote control, and the UAV will start headless mode, At the same time, the headless indicator of the remote control is always on; Press and hold again to cancel the headless mode, and the headless indicator of the remote control goes out

<p>GAO Group</p> <p>GAORFID.com</p> <p>GAOTek.com</p>	<p>Toll Free (USA & Canada)</p> <p>1-877-585-9555</p> <p>All Other Areas +1 (289) 660-5590</p> <p>sales@gaotek.com</p>
---	---