



<b>Product Name</b>	<b>Soil Meter PH Tester Sensor</b>
<b>Product SKU</b>	<b>GAOTek-IOTS-126</b>
<b>Product URL</b>	<b><a href="https://gaotek.com/product/gaotek-soil-meter-ph-tester-sensor/">https://gaotek.com/product/gaotek-soil-meter-ph-tester-sensor/</a></b>

**Contact us:** [sales@gaotek.com](mailto:sales@gaotek.com)

Based in New York City & Toronto, GAO Tek Inc. is ranked as one of the top 10 global B2B technology suppliers. GAO ships overnight within the U.S. & Canada & provides top-notch support thanks to its 4 decades of experience.



## Content

### Index

1. Product Overview .....	3
a. Introduction .....	3
b. Product Description.....	3
c. Applicable scenarios.....	3
d. Sensor Features .....	3
e. Precautions for use .....	3
2. Product Introduction .....	4
a. Product appearance.....	4
b. Power Supply Mode.....	4
c. Main Parameters of the product .....	4
3. System Architecture .....	6
a. 485 signal output .....	6
4. Installation Instructions and Wiring Instructions.....	6
a. Installation Instructions .....	7
b. Wiring Instructions.....	8
5. Communication Protocol and Host Computer Configuration .....	9
a. Version 485 Communication Protocol and description .....	9
b. Data Frame Format Definition .....	9
c. The upper computer reads the device data and software configuration .....	13
6. Failure Analysis and Warranty.....	18
a. Failure Analysis .....	18
b. Warranty Terms .....	19



## 1. Product Overview

### a. Introduction

Soil 7 in 1 sensor integrates sensing, acquisition and output. Compared with traditional IoT sensors, it has the advantages of high precision and easy installation.

### b. Product Description

It is suitable for the measurement of soil temperature, moisture, EC, NPK and PH. It is compared with the original German high-precision sensor and calibrated by the actual soil drying weighing method. It has high precision, fast response and stable output. It is less affected by soil salinity and is suitable for various soil types. It can be buried in the soil for a long time, resistant to long-term electrolysis, corrosion resistance, vacuum potting, and completely waterproof.

### c. Applicable scenarios

It is widely used in scientific experiments, water-saving irrigation, greenhouses, flowers and vegetables, grassland and pastures, soil rapid testing, plant cultivation, sewage treatment, grain storage and the measurement of water content and temperature of various particulate matter.

### d. Sensor Features

- This product adopts high-sensitivity digital probe with stable signal and high precision.
- Provide a variety of probes to meet the use of different environments.
- The equipment is beautiful and easy to install.
- The upper computer is simple to operate and easy to use.

### e. Precautions for use

- The steel needle must be fully inserted into the soil when measuring .
- Avoid strong sunlight directly on the sensor and cause the temperature to be too high. Pay attention to lightning protection when using in the field.



- Do not bend the steel needle violently, do not pull the sensor lead wire forcibly, and do not drop or violently hit the sensor.
- The sensor protection grade is IP68, and the whole sensor can be immersed in water.
- Due to the existence of radio frequency electromagnetic radiation in the air, it is not suitable to be energized in the air for a long time.

## 2. Product Introduction

### a. Product appearance



### b. Power Supply Mode

user provides a DC power supply with an input of 9~18v to the device. You can use the 220V AC to DC power supply provided by Gemho, or you can use 12V solar panels and batteries to supply power to meet the needs of different occasions.

### c. Main Parameters of the product

Performance	Parameter
Power supply	DC power supply 9-18V
Communication method	RS485/Analog 0-5V/0-10V/4-20mA

Based in New York City & Toronto, GAO Tek Inc. is ranked as one of the top 10 global B2B technology suppliers. GAO ships overnight within the U.S. & Canada & provides top-notch support thanks to its 4 decades of experience.



Measuring range	<p>Temperature: -40 °C ~ 80 °C</p> <p>Humidity : 0 ~ 100% ( non-condensing )</p> <p>PH : 0-14PH</p> <p>NPK : 0-1999mg/kg</p> <p>Conductivity: 0-2000us/cm</p>
precision	<p>Temperature: ± 0.5 °C</p> <p>Humidity: ±3% (when measuring frozen ice soil, the moisture value will be low and inaccurate)</p>
	<p>PH : 0.01PH</p> <p>NPK : ±2%Fs</p> <p>Conductivity : ±3% in the range of 0-1000us/cm; ±5% in the range of 1000-2000us/cm</p>
Resolution	<p>Temperature : 0.1 °C _</p> <p>Humidity: ± 1 % (when measuring frozen ice soil, the moisture value will be low and inaccurate)</p> <p>NPK : ±2%Fs</p> <p>Conductivity : 1 us/cm</p>
Response time	≤15s
Size	Length (72+70) mm width 45mm thickness 15mm
Operating temperature	-40°C~85°C
Working humidity	15%RH~90%RH (relative humidity), non-condensing
Adapt to stress	Atmospheric pressure ± 10%
Waterproof level	IP67

### 3. System Architecture

#### a. 485 signal output

The sensor is powered by 12V DC power supply, connected to a PLC with a 485 interface, and can also be connected to a single-chip microcomputer through a 485 interface chip. The microcontroller and PLC are programmed through the modbus protocol specified later. Or use USB to 485 to connect to a computer and use the sensor configuration tool provided by our company for configuration and testing. In theory, a bus can connect more than 16 485 sensors. If you need to connect more 485 sensors, you can use 485 repeaters to expand more 485 devices.

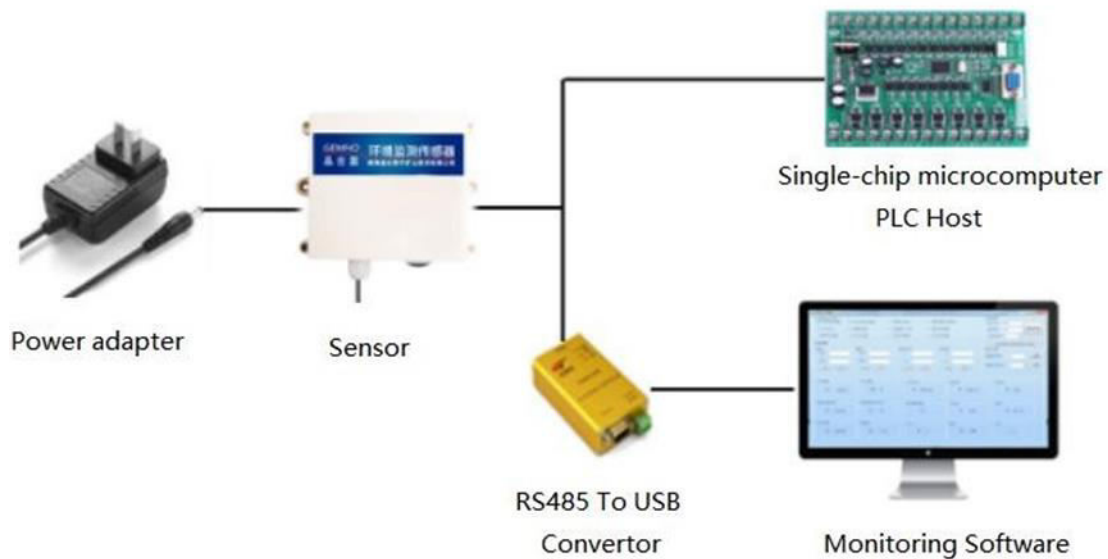

### 4. Installation Instructions and Wiring Instructions

- Equipment List
- Soil temperature and humidity PH nitrogen, phosphorus and potassium conductivity seven-in-one sensor 485/analog signal output version sensor equipment 1 set
- One copy of product certificate, warranty card and manual
- Power adapter (optional)

Based in New York City & Toronto, GAO Tek Inc. is ranked as one of the top 10 global B2B technology suppliers. GAO ships overnight within the U.S. & Canada & provides top-notch support thanks to its 4 decades of experience.



### a. Installation Instructions

- Adopts buried installation design.
- Dig a vertical hole in the soil environment to be detected and insert the sensor laterally into the soil (as shown in the figure below).

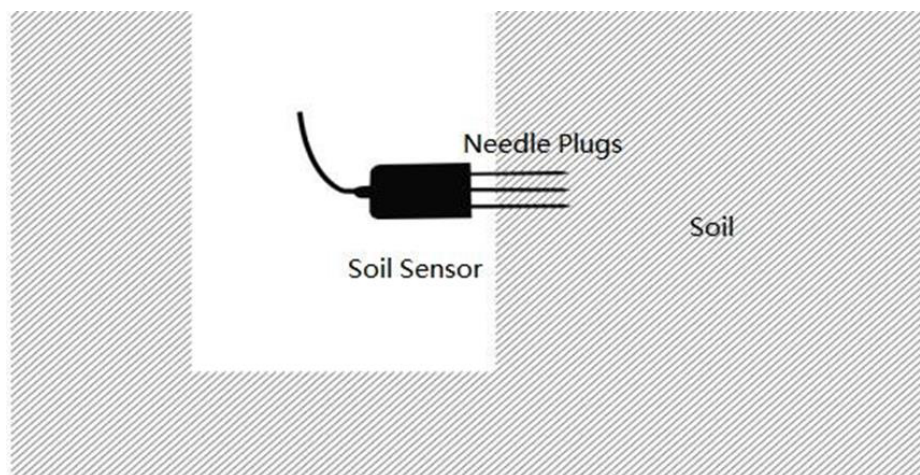



## b. Wiring Instructions

RS485 line sequence description

project	Line sequence name	thread color
power supply	Power is positive	red line
	negative power supply	black line
communication	RS485A	green line
	RS485B	yellow line

### Notice:

Please strictly follow the wiring sequence instructions, otherwise it is easy to cause excessive current and cause equipment damage. If the power adapter is not purchased from our company, it is equipped with a 4-core cable, and the customer needs to prepare a 9-18VDC power supply by himself. For customers who have purchased a power adapter from our company, we will connect the DC female connector to the device before the device leaves the factory. After the customer receives the product, the device can be powered directly by plugging it in. Occasionally, due to batch problems, the color of the line sequence does not match the instruction manual. Please refer to the line sequence printed by the laser on the back of the device.





## 5. Communication Protocol and Host Computer Configuration

### a. Version 485 Communication Protocol and description

Parameter	Content
coding	8 bit binary
data bits	8 bits
parity bit	none
stop bit	1 bit
error checking	CRC (Redundant Cyclic Code)
baud rate	9600bit/s

### b. Data Frame Format Definition

Using Modbus-RTU communication protocol, the format is as follows:

Initial structure  $\geq$  4 bytes of time

Address code = 1 byte

function code = 1 byte

data area = N bytes

Error check = 16-bit CRC

code time to end structure  $\geq$  4 bytes

Address code: the address of the transmitter, which is unique in the communication network (factory default 0x01).

Function code: The function prompt of the command sent by the host, this transmitter only uses the function code 0x03 (reading the memory data).



Data area: The data area is the specific communication data area, note that the high byte of the 16bits data is in front

CRC code: two-byte check code

### The temperature and humidity value of the device address 0X 01

#### Query frame:

Address code	Function code	Initial address	Data length	Checkcode low	Checkcode high
0x0 1	0x03	0x00, 0x0 6	0x00, 0x02	0x24	0x0A

#### Reply frame:

address code	function code	data bytes	temperature value	Humidity value	Check code low	Check code high
0x0 1	0x03	0x04	0x 06 , 0x A4	0x 01 , 0x 89	0x 8A	0x 01

#### Temperature:

06A4 (hex) = 1700 (dec) => temperature = 17.00 °C

#### Humidity:

0 292 (hexadecimal)=658 (decimal) => humidity= 6.58 %RH

Note: The temperature calculation method is the complement code method

If the returned value of temperature is FF17H (hexadecimal, original code)

Convert FF17 to binary as 1111111100010111



Then if the highest bit of the high byte is 1, it means that the temperature is negative Attachment: Complement knowledge extension (Baidu Encyclopedia).

<https://baike.baidu.com/item/%E8%A1%A5%E7%A0%81/6854613?fr=aladdin>

### Read the PH value of device address 0X 01

#### Query frame:

address code	function code	initial address	Data length	Checkcode low	Checkcode high
0x0 1	0x03	0x00, 0x0 9	0x00, 0x0 1	0x54 _	0x 08

#### Reply frame:

address code	function code	data bytes	pH value	Check code low	Check code high
0x0 1	0x03	0x04	0x 03 , 0x 2D	0x78 _	0x A9

#### PH:

032D (Hex) = 813 (Dec) => PH = 8.13

### Read the NPK concentration value of device address 0X01

#### Query frame:

address code	function code	initial address	Data length	Checkcode low	Checkcode high
0x01	0x03	0x00, 0x 1E	0x00, 0x0 3	0x65 _	0x CD

#### Reply frame:

addresses code	function code	data bytes	Nitrogen content	Phosphorus content	Potassium content	Check code low	Check code high



0x01	0x03	0x0 6	0x00 , 0x25	0x00 , 0 0x31	0x00, 0 0x 28	0x 41	0x 07
------	------	-------	----------------	------------------	------------------	-------	-------

25 (hexadecimal) = 37 (decimal) => nitrogen content = 37mg/kg

31 (Hex) = 49 (Dec) => Phosphorus content = 49mg/kg

28 (hexadecimal) = 40 (decimal) => potassium content = 40mg/kg

### Read the E-conductivity value of device address 0X 01

#### Query frame

address	function	initial	Data length	Checkcode	Checkcode
code	code	address		low	high
0x0 1	0x03	0x00, 0x0 8	0x00, 0x0 1	0x 05	0x C8

#### Reply frame

address	function	data bytes	Conductivity	Checkcode	Check code high
code	code		value	low	
0x0 1	0x03	0x04	0x 03 , 0x E8	0x58 _	0x FB

### E-Conductivity:

3E8 (Hex) = 1000 (Dec) => Conductivity = 1000us/cm

#### Query device address

Reading the current device address can only be done by a single sensor offline. Example for querying the device address:

Send: FF 03 00 0F 00 00 60 17

Returns: FF 03 01 01 00 60

The sensor return data 0x01 is the device address 0



### Example of modifying the device address

The communication protocol format of the written data is shown in the following table:

address	function	data	new address	Check code	Check code
code	code	address		low	high
	06	0x00, 0x0F	H, L		

**illustrate:**

1. The range of the address code is 0x01~0xFE, the default value is 0x01;
2. This machine only supports writing the sensor address value. When writing, the high bit of the address is in the front and the low bit is behind.

Example of writing sensor address:

Modify address 01 to address 09:

Send: 01 06 00 0F 00 09 79 CF

Return: 01 06 01 09 20 4

### c. The upper computer reads the device data and software configuration

#### Connect the device to the computer

The device is connected to the computer serial port through the "485 to USB" or "485 to 232" device.

#### Check if the device is connected

- 1) Open the computer device manager, check whether there are new devices under the ports (COM and LPT), and remember the port number of this device (the figure below is only a schematic diagram, the port numbers displayed by different computers are different)



## Read data

1) Run the "Environmental Monitoring Setting Software".

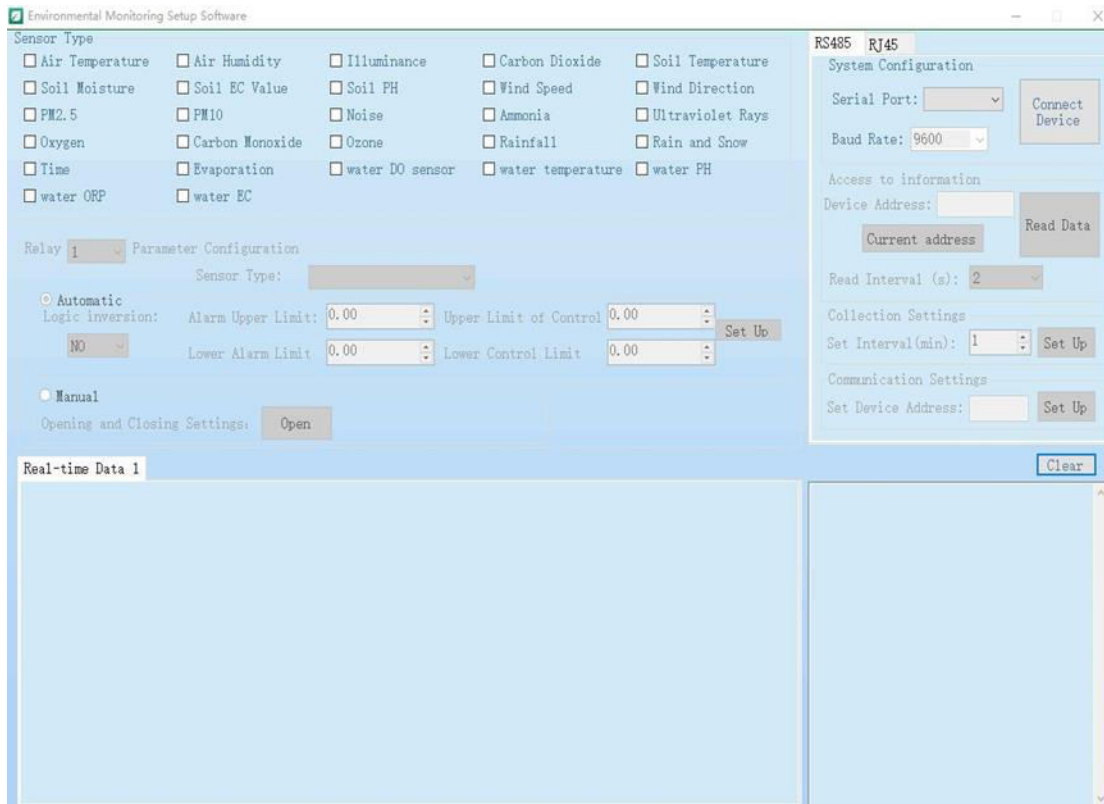

Based in New York City & Toronto, GAO Tek Inc. is ranked as one of the top 10 global B2B technology suppliers. GAO ships overnight within the U.S. & Canada & provides top-notch support thanks to its 4 decades of experience.



2) RS485 access equipment:

The screenshot shows a software interface for RS485 configuration. At the top, there are two tabs: 'RS485' (selected) and 'RJ45'. Below the tabs is the 'System Configuration' section with a 'Serial Port' dropdown menu and a 'Baud Rate' dropdown menu set to '9600'. A 'Connect Device' button is to the right. The 'Access to information' section has a 'Device Address' input field, a 'Current address' button, and a 'Read Data' button. Below that is a 'Read Interval (s)' dropdown menu set to '2'. The 'Collection Settings' section has a 'Set Interval (min)' dropdown menu set to '1' and a 'Set Up' button. The 'Communication Settings' section has a 'Set Device Address' input field and a 'Set Up' button.

Select the serial port number, baud. rate (default 9600, no need to select), click to connect the device.

This is a close-up of the 'System Configuration' section from the previous screenshot. The 'Serial Port' dropdown menu is now set to 'COM1'. The 'Baud Rate' dropdown menu remains set to '9600'. The 'Connect Device' button is still present to the right.

After the device is connected, the device address loading in [Information Acquisition] is completed; in [ Sensor Type Selection], the functions set in the current panel are checked by default; the list of checked functions is displayed in [Real-time Data]. As shown.

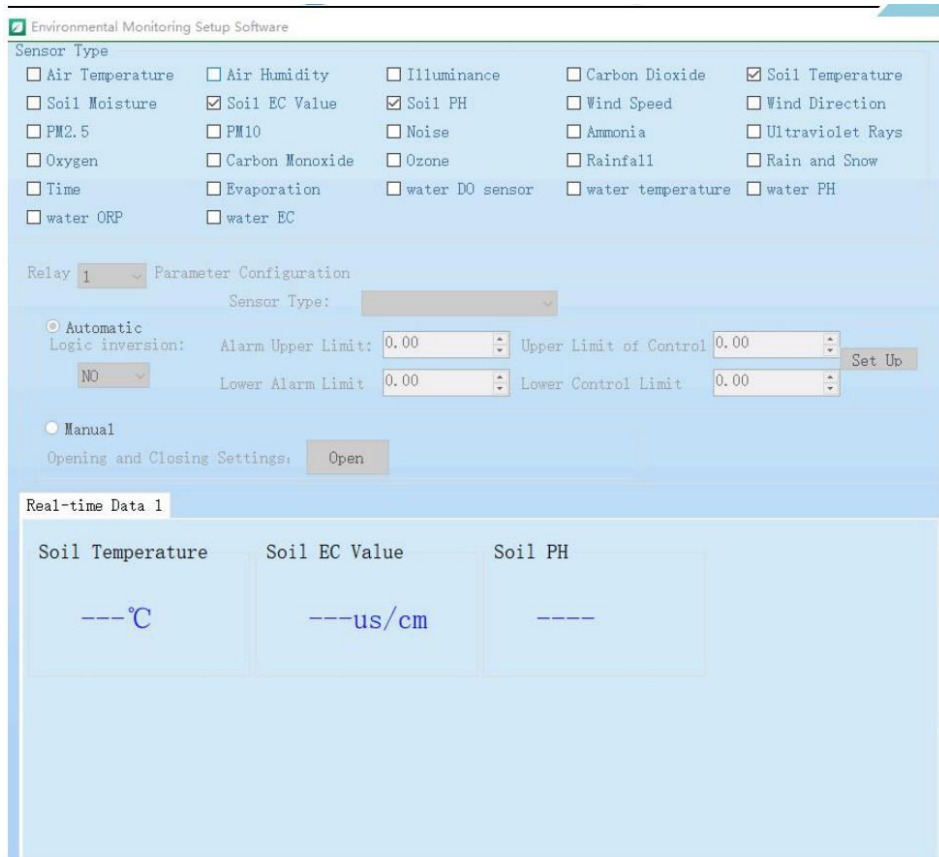

If the current device address is changed or empty, you can manually click the [Get Current Device Address] button to obtain the latest device address.

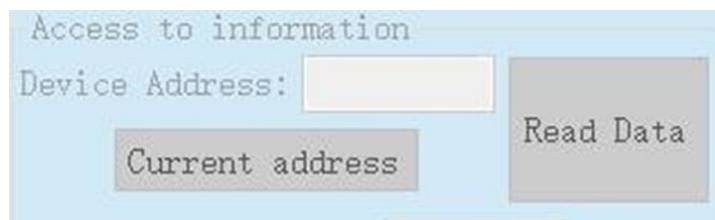

To modify the device address: select [Communication Settings], fill in the address to be modified in [Set Device Address], and click [Settings] to complete the modification.



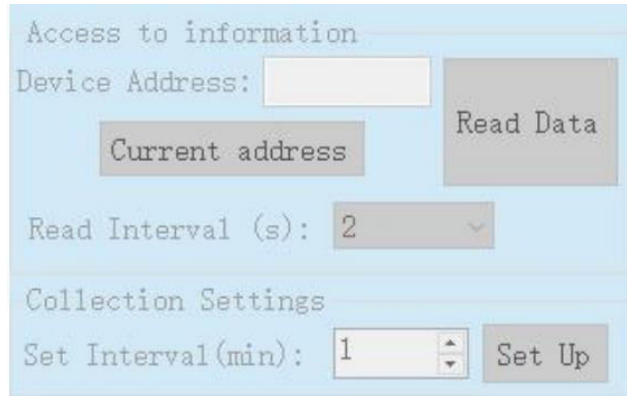

After the modification is completed, it will prompt that the modification is successful.



**To modify the baud rate of the device :**

select [Communication Settings], select the baud rate to be modified in [Serial Port Settings] - [Baud Rate], and click [Settings] to complete the modification.

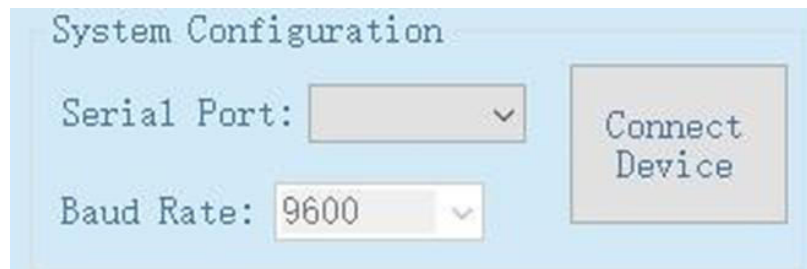

After the modification is completed, it will prompt that the modification is successful.



View device data on the host computer: select [collection interval], and then click [read data].  
The data appears as follows (cannot be exported):

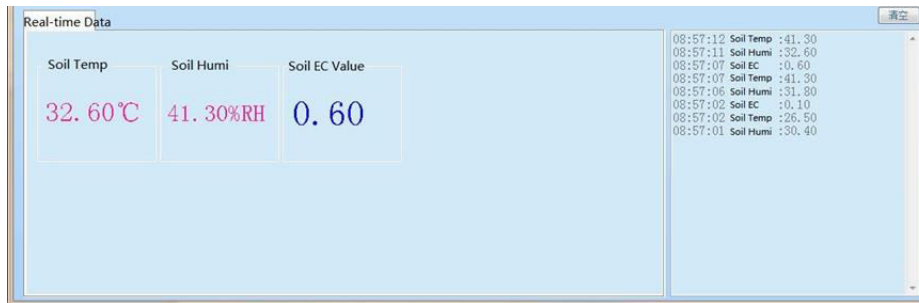

## 6. Failure Analysis and Warranty

### a. Failure Analysis

serial number	Phenomenon	possible failure	Solution
1	No communication signal	cable failure	Check the power supply circuit with a multimeter
2	Communication is normal, but no data	Interface connection failure	Check the interface connection
3	The measured data seriously deviates from the actual	Sensor failure	Contact the manufacturer



## **b. Warranty Terms**

This product is guaranteed for one year from the date of shipment, and the accessories (shell/plug/cable, etc.) are guaranteed for half a year.

The following conditions are not covered by the warranty:

- This type of product belongs to non-standard customization.
- Counterfeiting and imitation of our products.
- External factors or intentional damage, mechanical damage, violent smashing, etc.
- Damage caused by use in abnormal working environment and not according to the operation manual.
- The user disassembles, modifies or repairs the machine without authorization by the company.