



Product Name	GAOTek High Performance LCR Digital Bridge Meter
Product SKU	GAOTek-LCR-193
Product URL	https://gaotek.com/product/gaotek-high-performance-lcr-digital-bridge-meter/ -

Contact us: sales@gaotek.com



Table of Contents

Chapter 1 Out of Box Audit	7
1.1 To Inspect the package	7
1.2 Power connection.....	7
1.3 Fuse.....	7
1.6 Warm-up	8
1.4 Environment	8
1.5 Use of Test Fixture	8
Chapter 2 Introduction.....	9
2.1 Introduction to front panel	9
2.2 Introduction to rear panel.....	13
2.3 Introduction to display zone	15
2.4 Main menu keys and corresponding displayed pages.....	17
2.4.1 [MEAS DISP].....	17
2.4.2 [MEAS SETUP]	18
2.4.3 [SYSTEM].....	18
2.5 Basic Operation	18
2.6 Start the instrument.....	19
Chapter 3 Introduction to [MEAS DISP].....	21
3.1 <MEAS DISPLAY>.....	21
3.1.1 Test function.....	22
3.1.2 Test range	26
3.1.3 Test frequency	26
3.1.4 Test level	28
3.1.5 DC bias.....	29
3.1.6 Test speed.....	30
3.1.7 Tools.....	31
3.2 <BIN DISP>	33
3.2.1 Comparator function.....	34
3.2.2 BIN	34
3.2.3 HIGH/LOW	34
3.2.4 COUNT	34
3.2.5 AUX	35
3.2.6 OUT.....	35
3.3 <LIST SWEEP >	36
3.3.1 Sweep mode	37
3.3.2 FUN (Parameter)	38
3.3.3 FREQ [Hz] LEV[V] BIAS[x]	38
3.3.4 RESULT.....	38
3.3.5 COMP (Compare)	38
3.4 <MEAS SETUP>	39
3.4.1 Trigger mode	41



3.4.2 Auto level control function.....	43
3.4.3 Bias current isolation function	44
3.4.4 Average	45
3.4.5 Level monitor function.....	46
3.4.6 Delay time	47
3.4.7 Output impedance.....	48
3.4.8 Deviation test function	48
3.4.9 BIAS SRC	50
3.5 <CORRECTION>	53
3.5.1 OPEN.....	54
3.5.2 SHORT	57
3.5.3 LOAD.....	59
3.5.4 Load correction test function.....	62
3.5.5 Cable length selection	63
3.6 <LIMIT TABLE>.....	63
3.6.1 Swap parameter	65
3.6.2 Limit modes of compare function	65
3.6.3 Set nominal value of tolerance mode	67
3.6.4 Comparator function ON/OFF	68
3.6.5 Auxiliary bin ON/OFF	68
3.6.6 HIGH/LOW	70
3.7 <LIST SETUP>	72
3.7.1 MODE	73
3.7.2 Test parameter	73
3.7.3 Sweep parameter setup.....	74
Chapter 4 [SYSTEM] and <FILE>.....	75
4.1 <SYSTEM>.....	75
4.1.1 SKIN.....	75
4.1.2 LANGUAGE.....	76
4.1.3 PASS ALARM.....	76
4.1.4 FAIL ALARM.....	77
4.1.5 KEY SOUND	77
4.1.6 PASSWORD	78
4.1.7 SAVE TYPE.....	79
4.1.8 BUS MODE	79
4.1.9 GPIB ADDR (Reserved function).....	80
4.1.10 BAUD RATE	80
4.1.11 DATA/TIME.....	81
4.1.12 SYSTEM INFORMATION	81
4.1.13 FIRMWARE UPDATE	82
4.1.14 SYSTEM TEST	83
4.2 <FILE>	84



4.2.1 Setup file for single-group component (*.EST)	85
4.2.2 U-disk manage performance	86
4.2.3 Operation steps for file management.....	87
Chapter 5 Execute LCR operation and some examples	89
5.1 Correction operation	89
5.1.1 Sweep correction	89
5.1.2 Point-frequency correction	90
5.2 Correct connection of DUT	91
5.3 Eliminate the influence of stray impedance.....	93
5.4 Operation example for testing inductance with U2817A	94
5.5 Operation example of testing capacitance by multi-frequency list sweep	98
5.6 Operation example of load correction	102
Chapter 6 Performance and Test	105
6.1 Test function	105
6.1.1 Parameter and symbol	105
6.1.2 Test combination	105
6.1.3 Mathematical operation.....	105
6.1.4 Equivalent mode.....	105
6.1.5 Range.....	105
6.1.6 Trigger.....	106
6.1.7 Delay time	106
6.1.8 Connection modes of test terminals	106
6.1.9 Test speed (Frequency \geq 10kHz)	106
6.1.10 Average	106
6.1.11 Display digit.....	107
6.2 Test signal.....	107
6.2.1 Test signal frequency.....	107
6.2.2 Signal mode.....	107
6.2.3 Test signal level.....	107
6.2.4 Output impedance.....	108
6.2.5 Monitor for test signal level	108
6.2.6 Maximum measurement display range.....	108
6.3 Measurement accuracy	109
6.3.1 Accuracies of $ Z $, $ Y $, L, C, R, X, G, B.....	109
6.3.2 Accuracy of D	110
6.3.3 Accuracy of Q	110
6.3.4 Accuracy of θ	111
6.3.5 Accuracy of G	111
6.3.6 Accuracy of Rp.....	112
6.3.7 The accuracy of Rs	112
6.3.9 Accuracy of DCR	117
6.4 Safety requirement.....	117



6.4.1 Insulation resistance	118
6.4.2 Insulation intensity	118
6.4.3 Leakage current	118
6.5 Electromagnetic compatibility	118
6.6 Performance test	118
6.6.1 Working condition.....	118
6.6.2 The used instruments and devices	118
6.6.3 Function check	121
6.6.4 Test signal level.....	121
6.6.5 Frequency	121
6.6.6 Measurement accuracy	121
6.6.7 Accuracy of C and D	121
6.6.8 Accuracy of L.....	122
6.6.9 Accuracy of Z.....	122



Announcement

The description of the manual may not cover all contents of the instrument, and our company is subject to change and to improve the performance, function, inner structure, appearance, accessory and package of the instrument without notice. If there is puzzle caused by inconsistency of manual and instrument, then you can contact with our company by the address on the cover.



Chapter 1 Out of Box Audit

When you receive the instrument, some inspections are necessary, and the condition must be understood and available before installing the instrument.

1.1 To Inspect the package

Inspect the shipping container for damage after unpacking it. It is not recommended to power on the instrument in the case of a damaged container. If the contents in the container do not conform to the packing list, notify us or your dealer.

1.2 Power connection

- 1) Power-supplying voltage range: 99~243Vac. Being related with the power setup on the rear panel.
- 2) Power-supplying frequency range: 47~63Hz.
- 3) Power-supplying power range: less than 60VA.
- 4) Power supplying input phase line L, zero line N, ground lead E should be as same as the power plug of the instrument.
- 5) After careful design, the instrument can reduce the clutter jamming caused by AC power terminal input, however, it should be used under the environment with low-noise. Please install power filter if being unavoidable.

Warning: In order to prevent user and instrument from being hurt by leakage, it is necessary for user to guarantee the ground line of supply power being reliably grounded.

1.3 Fuse

The instrument has installed fuse, so operators should use the installed fuse of our company.



Warning: Be sure that the location of fuse is consistent with power-supplying voltage range before charging.

1.6 Warm-up

- 1) To guarantee the accurate measurement, the warm-up time is no less than 15min.
- 2) Please not turn on or off instrument frequently, in order to avoid the inner data fluster.

1.4 Environment

- 1) Please do not operate the instrument in the place that is vibrative, dusty, under direct sunlight or where there is corrosive air.
- 2) The normal working temperature is 0°C~40°C, relative humidity $\leq 75\%$, so the instrument should be used under above condition to guarantee the accuracy.
- 3) There is heat abstractor on the rear panel to avoid the inner temperature rising. In order to keep good airiness, please don't obstruct the left and right airiness holes to make the instrument maintain the accuracy.
- 4) Although the instrument has been specially designed for reducing the noise caused by ac power, a place with low noise is still recommended. If this cannot be arranged, please make sure to use power filter for the instrument.
- 5) Please store the instrument in the place where temperature is between 5°C and 40°C, humidity is less than 85%RH. If the instrument will not be put in use for a time, please have it properly packed with its original box or a similar box for storing.
- 6) The instrument, especially the test cable should be far from strong electro-magnetic field, to avoid the jamming on measurement.

1.5 Use of Test Fixture

Please use the accessory test fixture or cable, **the test fixture made by user or from other company may cause the incorrect measurement result.** The test fixture or cable should be kept clean, as well as the pin of DUT, thus to guarantee the good connection between DUT and fixture.



Connect the fixture or cable to four test terminals Hcur, Hpot, Lcur, Lpot on the front panel. As for the DUT with shielding shell, connect shielding layer or ground

“”.

Note: When test fixture or cable has not being installed, the instrument will display an unstable test result.

1.7 Other features

- 1) Power: consumption power \leq 60VA.
- 2) Dimension (W*H*D): 350mm*120mm*360mm
- 3) Weight: About 3.5kg.

Chapter 2 Introduction

In this chapter, the basic operation features of U2817A are described. Please read the content carefully before using U2817A instruments, thus you can learn the operation of U2817A.

2.1 Introduction to front panel

Figure 2-1 shows the front panel of U2817A.

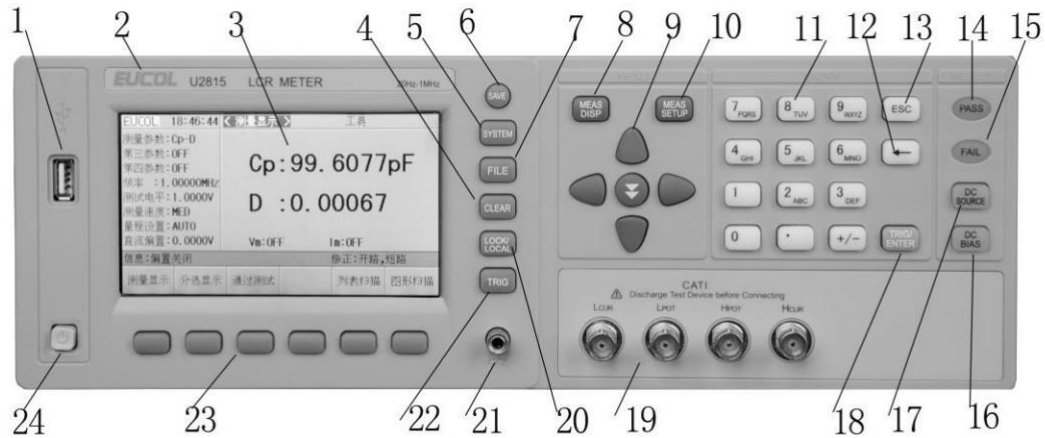

1) USB HOST interface

Connect U flash disk so as to save or use a specified file.

2) Brand and model

Brand and model

3) LCD

480*272 colorful TFT LCD displays measurement results and conditions.

4) [CLEAR]

Execute the calibration operation. Press this key to execute OPEN/SHORT calibration.

5) [SYSTEM]

Press this key to enter into the system setup page.

6) [SAVE]

Copy the currently displayed page to USB memory.

7) [FILE]

Press [FILE] key enter into the display page of file list.

8) [MEAS DISP]



Press this key to enter into the display page of measurement display.

9) CURSOR

This key is used to move the cursor on the LCD displayed page. When the cursor moves to a zone, the corresponding zone will be lightened.

10) [MEAS SETUP]

Press this key to enter into the setup page of measurement setup.

11) Numerical keys

These keys are used to input data to the instrument. The key consists of numerical keys [0] to [9], decimal point [.] and [+/-] key.

12) [←]

BACKSPACE key is used delete the last numeric of the input value.

13) [ESC]

ESCAPE
key

14) PASS indicator

LED indicator shows the test result has passed.

15) FAIL indicator

LED indicator shows the test result has failed.

16) [DC SOURCE]

This key is used to permit or forbid the output of a 10V individual voltage source.

17) [DC BIAS]

[DC BIAS] is used to permit or forbid the output of 0-100mA/10V DC bias source. Press this key, it will be lighted which means DC bias output is permitted. Press this



key once more, it will be off which means DC bias output is prohibited. The key is useless in some pages where the DC BIAS cannot be added.

18) [TRIG/ENTER]

This key is used to end the input of data, and confirm and save the data displayed on the inputting line (the bottom line on LCD).

When the trigger mode is set to MAN mode, press this key to trigger the instrument.

19) Test terminals (UNKNOWN)

4-terminal test pair are used to connect 4-terminal test fixture or cable to measure DUT.

The 4 terminals are respectively as follows: Hcur, Hpot, Lpot and Lcur.

20) [LOCK/LOCAL]

Press this key, the buzzer will beep, which means the function of current panel is locked. Press it again, it will be off, which means discharging the lock status. If the password function is ON, it means correct password is necessary when discharging the key-lock, or the key cannot be unlocked.

21) Ground terminal

The ground terminal is connected with the case of instrument, which can be used to protect or shield the ground connection.

22) [TRIG]

When the trigger mode is set to MAN mode, press this key to trigger the instrument.

23) Soft keys

Six soft keys are used to select parameters. The corresponding function of each soft key has been displayed on its left (the right part of LCD). The function definition varies with different pages.

- 24) POWER
 - Power switch

2.2 Introduction to rear panel

Figure 2-2 shows the rear panel of U2817A.

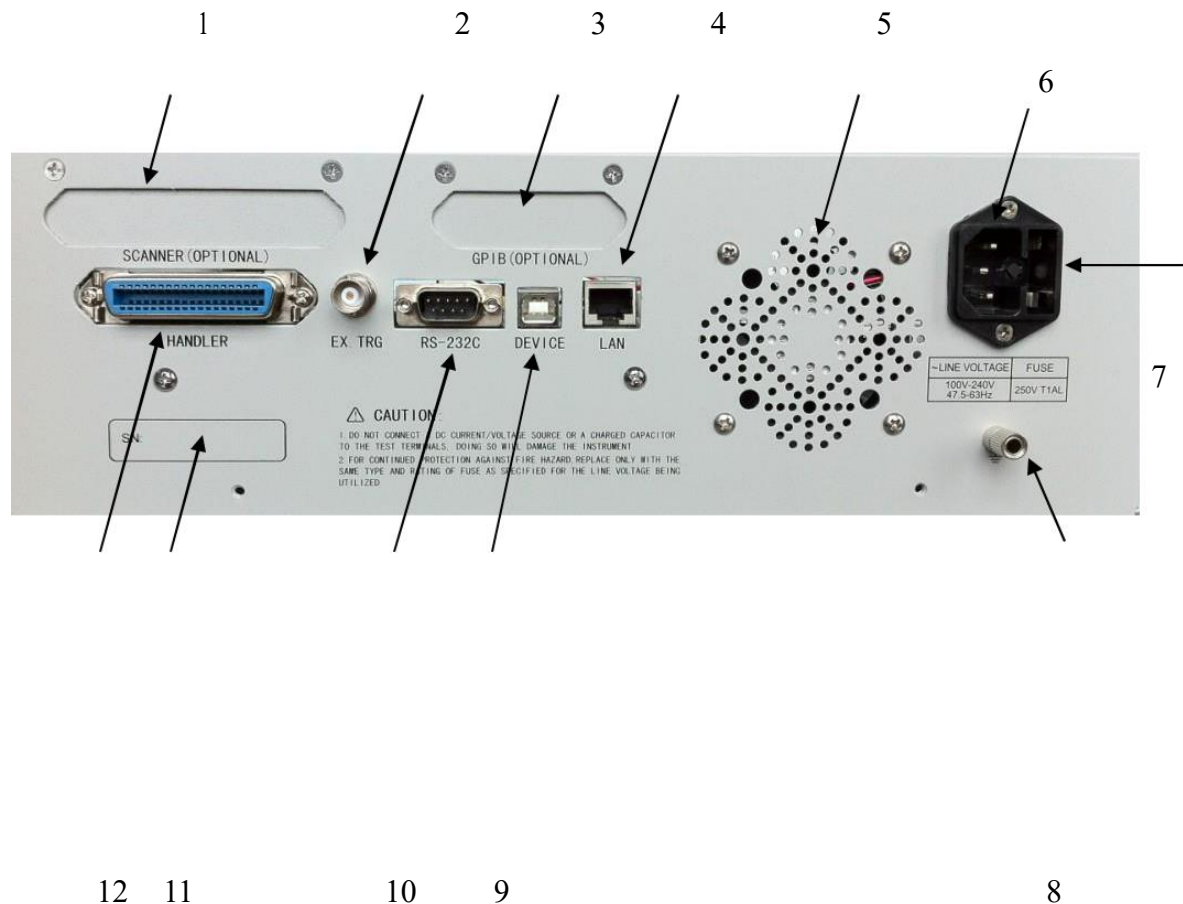

Figure 2-2 Rear panel

- 1) SCANNER interface (Option)

Control the transformer scanning box through SCANNER interface.



2) External trigger interface

Handler interface is used to realize the sorting output of test results.

3) IEEE-488 interface (Option)

The tester can communicate with PC through GPIB interface.

4) LAN interface (Option)

LAN interface is used to realize the control and the communication of network system.

5) Fan window

Heat elimination, maintaining the normal working temperature

6) Power socket

Input AC power.

7) Fuse base

Being used to install power fuse, protect instrument.

8) Ground terminal

Connect the case with the ground.

9) USB DEVICE interface

The tester can communicate with PC through the USB DEVICE interface.

10) RS232 interface

Series communication interface can realize the communication with PC.

11) Serial number

Information about production date, instrument number and manufacturer etc..

12) HANDLER interface



Handler interface is used to realize the sorting output of test results.

Warning: Be sure that the direction of fuse is accordant with power-supply voltage range before charging.

13) Ground terminal

The ground terminal is connected with instrument casing, being available for protecting or shielding ground connection.

2.3 Introduction to display zone



U2817A applies a 65k, 5-inch TFT display. The display screen is divided into the following zones:

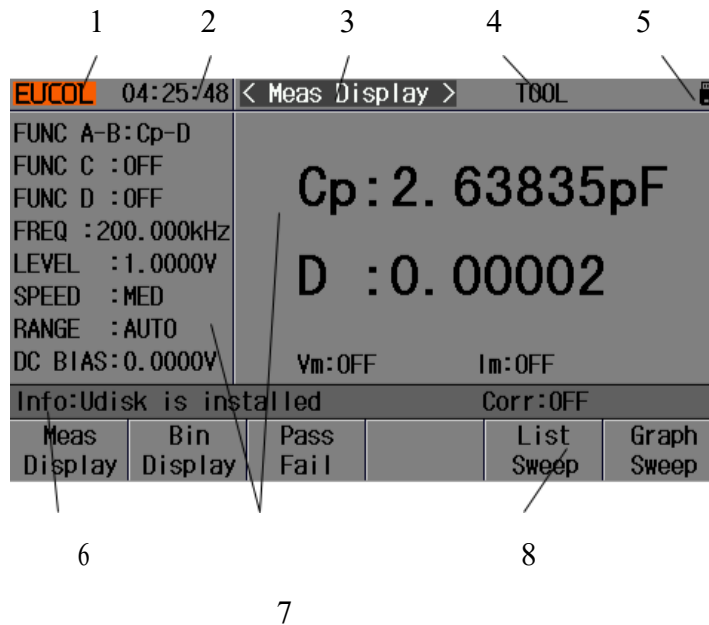

Figure 2-3 display zones

1) Logo

Display the logo of the company.

2) Time

Display the current time.

3) Display page name

Indicate the name of the currently displayed page.

4) Tools menu

When the cursor moved the area, the softkey area will display the corresponding specific tools

5) System icon zone

In this zone, display the system status:



U disk is connected



- Remote control status.
- Keyboard locked.
- Data recording status. **DC** DC bias is opened.

6) Help

In this zone, information about system and user data input is displayed.

7) Test result/ condition display zone

In this zone, test result information and current condition are displayed.

8) Soft keys

The zone is used to display the function definition of soft key. The definition of soft key can be different as the difference of cursor's direction in the zone.

2.4 Main menu keys and corresponding displayed pages

2.4.1 [MEAS DISP]

Press this key-[**MEAS DISP**] to enter into the LCR measurement display page, the following soft keys will be displayed in the soft key zone.

<**MEAS DISPLAY**>

<**BIN DISPLAY**>

<**PASS FAIL**>

<**LIST SWEEP**>

<**GRAPH SWEEP**>



2.4.2 [MEAS SETUP]

Press this key-[MEAS SETUP], the following soft keys will be displayed in the soft key zone on the LCR measurement setup page.

<MEAS SETUP>

<CORRECTION>

<LIMIT TABLE>

<LIST SETUP>

<GRAPH SETUP>

2.4.3 [SYSTEM]

This key-[SYSTEM] is used to enter into the system setup page. The following soft keys will be available:

<SYSTEM SETUP>

<SYSTEM INFO>

<FIRMWARE UPDATE>

<SYSTEM TEST>

2.5 Basic Operation

Basic operation of U2817A is as follows:

Use menu keys ([MEAS DISP], [MEAS SETUP], [SYSTEM]) and soft keys to select the desired page.

Use cursor keys ([←][→]) to move the cursor to the desired zone. When the cursor moves to a specified zone, the zone will become reverse expression.



The soft key functions corresponding to the current zone of the cursor will be displayed in the soft key zone. Users can select and use the desired key. Numeric keys, [BACKSPACE] and [ENTER] are used to input data.

When a numeric key is pressed down, the usable unit soft key will be displayed in the soft key zone. You can choose a unit soft key or press [ENTER] to end data inputting. When [ENTER] is used to terminate data inputting, the unit of data will be set to a default unit, such as Hz, V or A. For example, the default unit for frequency is Hz.

2.6 Start the instrument

Plug in 3-line power plug.

Caution: Keep the power-supply voltage and frequency conform to above specifications. Power input phase line L, zero line N, ground line E should be the same as that of the instrument.

Press the power switch at the left corner on the front panel and then a boot screen will appear which displays our company logo.





If the password protection function is on, users are required to input the password and then press [ENTER] to enter into the page of main menu.

Note: The instrument has a **default password-123456**. In your practical use, you can change it and set your own one. Please see <SYSTEM> section for more information.



Chapter 3 Introduction to [MEAS DISP]

3.1 <MEAS DISPLAY>

Press [MEAS DISP], the <MEAS DISPLAY> page will be displayed on screen as shown in the following figure.

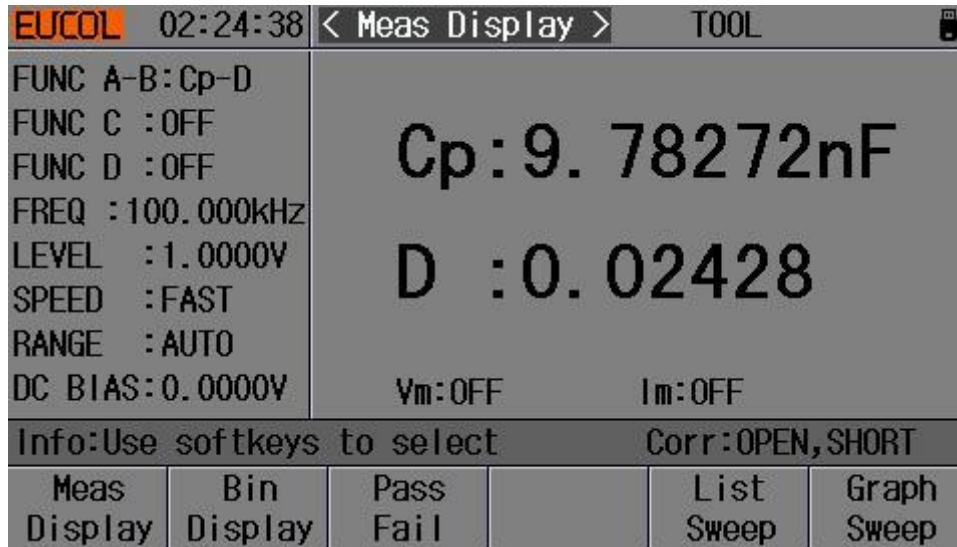

On this page, the test result is displayed in right area. The measurement control parameters can be set in this page:

- Test function (FUNC A-B)
- Test function (FUNC C)
- Test function (FUNC D)
- Test frequency (FREQ)
- Test level (LEVEL)
- Test speed (SPEED)



Test range
(RANGE) DC bias

There are 8 zones in this page: FUNC A-B, FUNC C, FUNC D, FREQ, LEVEL, RANG, SPEED, DC BIAS. The details will be discussed later.

The test result/ condition display zone shows the information about test condition.

These conditions can be set on <Meas Setup> page or <Correction> page.

Signal source voltage/ current monitor (**Vm, Im**)

Open, short, load correction ON/OFF status (**CORR**)

3.1.1 Test function

In a measurement period, U2817A can test four parameters for an impedance component. Parameters that can be tested are as follows:

Primary parameters

|Z| (Module of impedance) |Y|
(Module of admittance) L
(Inductance)

C (Capacitance) R
(Resistance) G
(Conductance)

DCR (DC resistance)

Secondary Parameters

D (Dissipation factor) Q
(Quality factor)

Rs (Equivalent Series Resistance ESR) Rp
(Equivalent Parallel Resistance)



X (Reactance)

B (Admittance)

θ (Phase Angle)

Test results of primary and secondary parameters are respectively displayed in two lines in the form of upper-case characters. The primary parameter displays in the upper line while the secondary parameter displays in the lower line. Operation steps for setting test function:

- 1) Move the cursor to FUNC A-B zone, the following soft keys will be displayed on the screen.

OFF

Cp—D

Cp—Q

Cp—G

Cp—

Rp

More

- 2) Select and press a softkey to set test function. If the softkey you need is not displayed on the page, press **More** to display the following softkeys.

Less

Cs—D

Cs—Q

Cs—

Rs

More

- 3) Select and press a softkey to set test function. If the softkey you need is not displayed on the page, press **More** to display the following softkeys.



Less

Lp—D

Lp—Q

Lp—G

Lp—

Rp

More

- 4) Select and press a softkey to set test function. If the softkey you need is not displayed on the page, press **More** to display the following softkeys.

Less

Ls—D

Ls—Q

Ls—

Rs

More

- 5) Select and press a softkey to set test function. If the softkey you need is not displayed on the page, press **More** to display the following softkeys.

Less

R—X

Z—

θr



Z— θ°

Rs—

Q

More

- 6) Select and press a softkey to set test function. If the softkey you need is not displayed on the page, press **More** to display the following softkeys.

Less

G—

B

Y—

θ_r

Y— θ°

Rp—

Q

More

- 7) Select and press a softkey to set test function. If the softkey you need is not displayed on the page, press **More** to display the following softkeys.

Less

Ls—

DCR

Lp—

DCR



Parameter setup of **FUNC C** and **FUNC D** are the same as that of **FUNC A-B**, but **FUNC C and FUNC D** is only choice one parameter.

3.1.2 Test range

Measurement range should be selected in accordance with the impedance value of the tested LCR component.

U2817A has 10 AC measurement ranges: 1Ω, 10Ω, 30Ω, 100Ω, 300Ω, 1kΩ, 3kΩ, 10kΩ, 100kΩ, 1MΩ.

Operation steps for setting test range:

1) Move the cursor to the range zone, the following soft keys will be displayed:

AUTO The soft key is used to set the range mode to **AUTO**.

HOLD The soft key is used to switch the **AUTO** mode to the **HOLD** mode. When the range mode is set to **HOLD**, the range will be locked in the current measurement range. The current measurement range will be displayed in the range zone.

INCR+ The soft key is used to increase the range under **HOLD** mode. **DECR-** The soft key is used to decrease the range under **HOLD** mode.

2) Use soft keys to set measurement range.

3.1.3 Test frequency

The measurement range of U2817A ranges from 50Hz to 100kHz with an increase or decrease of 0.01Hz.

Operation steps for setting test frequency:

U2817A provides two methods to set measurement frequency. The first one is to use soft keys and the other one is to input data by using numeric keys.

1) Move the cursor to the **FREQ** zone, the following soft keys will be displayed.

**INCR++**

This is a coarse adjustment soft key used to increase the frequency. Press this key, the frequency will change as the following sequence: 20Hz, 100Hz, 1kHz, 10kHz, 100kHz.

INCR+

This is a fine adjustment soft key used to increase the frequency. Press this key, the frequency will switch between the following ones:

20 Hz 100 Hz 1 kHz 10 kHz 100 kHz

25 Hz	120 Hz	1.2 kHz	12 kHz
30 Hz	150 Hz	1.5 kHz	15 kHz
40 Hz	200 Hz	2 kHz	20 kHz
50 Hz	250 Hz	2.5 kHz	25 kHz
60 Hz	300 Hz	3 kHz	30 kHz
80 Hz	400 Hz	4 kHz	40 kHz
	500 Hz	5 kHz	50 kHz
	600 Hz	6 kHz	60 kHz
	800 Hz	8 kHz	80 kHz

DECR-

This is a fine adjustment soft key used to decrease the frequency. The selectable frequencies are the same as that of **INCR+**.



DECR--

This is a coarse adjustment soft key used to decrease the frequency. The selectable frequencies are the same as that of INCR++.

- 2) Use soft keys or numeric keys to select or set frequency. When using numeric keys to input the required frequency value, the soft key displays the available frequency units (Hz, kHz and MHz). You can use unit soft key to input unit and data. When using [ENTER] to input frequency, the default unit is Hz.

3.1.4 Test level

The measurement level of U2817A can be set according to the RMS value of sine wave signal. The frequency of sine wave signal is the test frequency which is generated by inner oscillator. You can set measurement voltage or current. The output impedance of U2817A signal source can be 10Ω, 30Ω or 100Ω.

Note: The measurement current is the output one when the tested terminal is short, while the measurement voltage is the output one when the tested terminal is open.

The auto level control function of U2817A can realize the measurement of constant voltage or current. The auto level control function (ALC) can be set as ON in <MEAS> page. When the auto level control function is set to ON, "*" will be displayed following the current level value. Refer to <MEAS> for more information.

Operation steps for setting test level:

U2817A provides two methods to set the level of test signal source. The first one is to use soft keys, while the second one is to input data by numeric keys.

- 1) Move the cursor to LEVEL, the following soft keys will be displayed.

**INCR+**

This soft key is used to increase the level of test signal source.

DECR-

This soft key is used to decrease the level of test signal source.

- 2) Soft or numeric keys are used to select or set the test level. When numeric keys are used to input the desired level, the available units (mV, V, μ A, mA and A) will be displayed in the soft key zone. Users can use these unit keys to input unit and data. When [ENTER] is used to terminate the input of level, the default level is V or A.

NOTE: When you need to switch the level between current and voltage, numeric keys and unit soft keys must be used.

3.1.5 DC bias

U2817A provides internal DC bias voltage from -5V to +5V.

Operation steps for setting DC bias:

U2817A provides two methods to set the DC bias. The first one is to use soft keys, while the second one is to input data by numeric keys.

- 1) Move the cursor to DC BIAS, the following soft keys will be displayed.

INCR+



This soft key is used to increase the output level of DC bias.

DECR-

This soft keys is used to decrease the output level of DC bias.

- 2) Soft or numeric keys can be used to select or set the DC bias source. When numeric soft keys are used to input the desired bias level, the available units ((mV, V, μ A, mA and A) will be displayed in the soft key zone. Users can use these soft keys to input unit or data. When [ENTER] is used to terminate the input of bias value, the default unit is V or A.

NOTE: When you need to switch the DC bias level between current and voltage, numeric keys and unit soft keys must be used.

Press the [DC BIAS] key on the front panel to allow the output of DC bias. When DC bias is permitted to output, the [DC BIAS] key will be lighted.

3.1.6 Test speed

The test speed of U2817A is determined by the following factors:

Integration time (A/D conversion)



Average times (average test times per each test)

Measurement delay (from startup to the start of measurement)

Display time of test results

You can select test mode as FAST, MED or SLOW. Generally, the test result is more stable and accurate in SLOW test mode.

Operation steps for setting test speed:

- 1) Move the cursor to SPEED, the following soft keys will be displayed:

FAST

MED

SLOW

- 2) Use above soft keys to set the test speed.

3.1.7 Tools

The test result of U2817A is displayed as 6 floating-point digits. Decimal point lock function can make U2817A output the test result in fixed way. Meanwhile this function can change the displayed count of test result. This displayed result can be selected to be shown in large character or small character.

Operation steps for tools

Set the display mode of decimal point in fixed mode according to the following operation steps. Also the character size of test result can be set.

- 1) Move the cursor to TOOL zone, the following soft keys will be displayed:

D.P. AUTO



**D.P.FIX A D.P.
FIX B**

**FULL SCREEN
DISP OFF ON**

- 2) Press **D.P. AUTO** to reset the decimal position of the primary or the secondary parameter test result to its default setting.
- 3) Press **D.P.FIX A** to lock the decimal location of primary parameter TEST result. When the decimal location is locked, “▲” is displayed. Press **D.P.FIX A** once, the last digit will be deleted, and the displayed digit will be reduced by one.
- 4) Press **D.P.FIX B** to lock the decimal location of secondary parameter TEST result. When the decimal location is locked, “▲” is displayed. Press **D.P.FIX B** once, the last digit will be deleted, and the displayed digit will be reduced by one.
- 5) Press **FULL SCREEN** to display the test results on full screen.

- 6) Press **DISP OFF ON** to close/open the display of the test results.

NOTE: Under the following circumstance, the function of decimal lock will be cancelled automatically to recover to floating decimal point status.

Test function is changed.

In deviation test, the deviation test mode (Δ ABS, Δ %, OFF) is changed.



3.2 <BIN DISP>

Press [MEAS DISP] firstly and then the **BIN DISPLAY** soft key to enter into <BIN DISPLAY> display page. On this page, bin NO. is displayed in upper-case character while the test result, in lower-case character.

EUCOL 00:15:10		< Bin Display >		TOOL		
NOM : 10.0000nF	BIN	LOW	HIGH	COUNT		
BIN CMP: OFF	1	100.000pF	1.00000nF	0		
COUNTER: OFF	2	1.00000nF	2.00000nF	0		
BIN:	3	-----	-----	0		
	4	-----	-----	0		
	5	-----	-----	0		
	6	-----	-----	0		
	7	-----	-----	0		
	8	-----	-----	0		
	9	-----	-----	0		
	Cp: 9.78822nF	REJECT	AUX: 0	OUT: 0		
	D : 0.00220	Info: Use softkeys to select		Corr: OFF		
OFF	ON					

The following control parameters can be set on <BIN DISPLAY>.

Compare function ON/OFF (**BIN CMP**)

Count function ON/OFF (**COUNTER**)

The following test result/ condition can be displayed in this page but cannot be set in this page. Users can set them on the <LIMIT TABLE > page.



Nominal value (NOM)

Bin limit value (HIGH/ LOW)

3.2.1 Comparator function

U2817A has an inserted compare function which can divide DUT to up to 10 bins (from BIN1 to BIN9 and BIN OUT). Users can set 9 pairs of primary parameter limit and one pair of secondary bin limit. If the primary parameter of DUT is within the range of the bin limit but the secondary parameter is outside of the bin limit, the DUT will be sorted into the auxiliary bin. When U2817A has installed an HANDLER

interface, the compare result will be output into the automatic test system and further realizing auto-sorting test. These limits can only be set on the <LIMIT TABLE > page. Users can set the compare function to ON or OFF in the **BIN CMP** zone.

Operation steps for compare function

- 1) Move the cursor to **BIN CMP**, the following soft keys will be displayed. **ON**
OFF
- 2) Select one of above soft keys to set the compare function as ON or OFF.

3.2.2 BIN

This zone shows the bin number of the limit list.

3.2.3 HIGH/LOW

This zone shows the high and the low limits of the limit list.

3.2.4 COUNT



This zone shows the count value of the current bin.

3.2.5 AUX

This zone shows the count value of the auxiliary bin.

3.2.6 OUT

This zone shows the count value of the out bin.

Operation steps for bin count function

Execute the following operations to set the bin count function ON/OFF on <BIN DISPLAY> page.

- 1) On < BIN DISPLAY> page, move the cursor to **COUNTER** zone, the following soft keys will be displayed.

ON
OFF
F

- 2) Press the soft key **ON** to turn on the count function.
- 3) Press the soft key **OFF** to turn off the count function.
- 4) On < BIN DISPLAY> page, move the cursor to **TOOL** zone, the following soft keys will be displayed.
CLEAR COUNTER
- 5) Press the soft key **CLEAR COUNTER**, “Info: Sure clear bin counter?” will be displayed in the help zone. Then the following soft keys will be displayed.



YES

NO

- 6) Press the soft key **YES** to reset all bin counts to 0.
- 7) Press the soft key **NO** to cancel the reset operation.

3.3 <LIST SWEEP >

Up to 10 test frequencies, test levels or DC bias can be set on this page. Users can set the high and the low limits for each list-sweep test point. Auto sweep test will be made on these test points. And their test results will be compared with their limits.

Press down the menu key [**MEAS DISP**] and then the soft key **LIST SWEEP** to enter into the <**LIST SWEEP**> page, shown as below.

No.	FUN	CHH-CHL	FREQ[Hz]	LEV[V]	BIAS[x]	RESULT	COMP
0	Cs	0 - 0	1.00000k	1.0000		9.78801nF	
*1	D	0 - 0	10.0000k	1.0000		0.00692	
2	Z	0 - 0	1.00000k	1.0000		16.2604kΩ	
3	Z	0 - 0	10.0000k	1.0000		1.62680kΩ	
4							
5							
6							
7							
8							
9							

Info:Use softkeys to select				Corr:OFF	
Meas Display	Bin Display	Pass Fail		List Sweep	Graph Sweep



Test points will be automatically tested in a scanning mode. Meanwhile, comparison will be made between test results and limit values. In the process of list sweep test, “*” denotes the current sweep test point. List sweep points cannot be set on this page but can be set on <LIST SETUP>.

3.3.1 Sweep mode

The list sweep function of U2817A can make automatic sweep test for up to 10 points’ test frequencies, test levels or DC bias. Two sweep modes are available on U2817A: SEQ and STEP. In SEQ mode, each press of [TRIG] will direct U2817A to automatically test all list sweep test points. In STEP mode, each press of [TRIG] will direct U2817A to test one list sweep point.

NOTE: When the trigger mode is set to INT, sweep test modes of SEQ and STEP will not be controlled by [TRIG].

When the trigger mode is set to MAN, [TRIG] can be used to trigger the list sweep test.



Operation steps for setting the list sweep mode:

Set the sweep mode on the <LIST SWEEP> page as **SEQ** or **STEP**.

- 1) On the < **LIST SWEEP**> page, move the cursor to the **TOOL** zone, the following soft keys will be displayed:

MODE

STP FAIL

- 2) Press **MODE** to set the sweep mode as sequential/single step sweep test mode.
- 3) Press **STP FAIL** to set the stop sweep mode as continue/pause/retry/stop when the test results is out of limit value.

3.3.2 FUN (Parameter)

This zone is the currently swept Function parameter. What are right below this item are the sweep results.

3.3.3 FREQ [Hz] LEV[V] BIAS[x]

This zone shows the currently swept parameter mode and its unit. What are right below this item are parameters of the sweep list.

3.3.4 RESULT

This zone shows what are right below this item are the sweep results.

3.3.5 COMP (Compare)

This zone indicates the compare results of the currently swept points. L means the result is lower than the standard and H is higher than the standard, while blank is medium.



3.4 <MEAS SETUP>

Press [MEAS SETUP] to enter into the <MEAS SETUP> page shown as

EUCOL 00:23:31		< Meas Setup >		TOOL	
FUNC A-B: Cp-D		TRIG : MAN	VAC MON : OFF		
FUNC C : OFF		TRG DLY: 0ms	IAC MON : OFF		
FUNC D : OFF		SRC IMP: 100Ω	DEV A : OFF		
FREQ : 100.000kHz		AVG : 1	REF A : 0.00000pF		
LEVEL : 1.0000V		AUTO LCR: OFF	DEV B : OFF		
SPEED : FAST		ALC : OFF	REF B : 0.00000p		
RANGE : AUTO		DCI ISO: OFF	STEP DLY: 0ms		
DC BIAS: 0.0000V		BIAS SRC: INT	DC SRC : 0.0000V		
Info: Use softkeys to select					
Meas Setup	Correc tion	Limit Table		List Setup	Graph Setup



In this page, the following control parameters can be set. (Items in parenthesis can be set)

Test function (**FUNCA-B**)

Test function (**FUNC C**)

Test function (**FUNC D**)

Test frequency (**FREQ**)

Test level (**LEVEL**)

Test speed (**SPEED**)

Test range (**RANGE**)

DC Bias (**DC BIAS**)

Trigger Mode (**TRIG**)

Delay Time (**TRG DLY**)

Output Resistance (**SRC IMP**)

Average times (**AVG**)

Auto LCR Function(**AUTO**
LCR) Auto Level Control (**ALC**)

Bias Current Isolation ON/ OFF (**DCI ISO**)

Bias Current Source(**BIAS SRC**)



Voltage Level Monitor ON/ OFF (**VAC MON**)

Current Level Monitor ON/ OFF (**IAC MON**)

Deviation Test Mode A (**DEV A**)

Deviation Test Reference Value A (**REF A**)

Deviation Test Mode B (**DEV B**)

Deviation Test Reference Value B (**REF B**)

Step Delay Time(**STEP DLY**)

DC Voltage Source (**DC SRC**)

Some zones listed below are as same as that on <MEAS DISP> page, so it is not necessary to introduce in this section, but others will be introduced briefly in the following sections.

Test function (**FUNC A-B**)

Test function (**FUNC C**)

Test function (**FUNC D**)

Test frequency (**FREQ**)

Test level (**LEVEL**)

Test range (**RANGE**)

Test speed (**SPEED**)

DC Bias (**DC BIAS**)

3.4.1 Trigger mode

There are 5 trigger modes on U2817A: INT, MAN, EXT DUT and BUS.

When the trigger mode is set as INT, U2817A will make sequential and repeated tests.



When the trigger mode is set as MAN, press [TRIG] once, U2817A will make one test. When the trigger mode is set as EXT, once the HANDLER interface receives a positive impulse, U2817A will execute one measurement.

When the trigger mode is set as DUT, once the test fixture receives a component, U2817A will execute one measurement.

When the trigger mode is set as BUS, once the IEEE 488 interface receives a TRIGGER command, U2817A will execute a test. The BUS mode cannot be set on the front panel.

Note: In the process of testing, when U2817A receives a trigger signal, it will be ignored. So the trigger signal should be sent after the test is done.

When optional HANDLER interface triggers U2817A, the trigger mode is set as EXT.

Operation steps for the trigger mode setup

Execute the operation of other trigger modes except BUS trigger. If BUS trigger mode is necessary, then use IEEE4888 interface to send **TRIGger:SOURce BUS** command.

- 1) Move the cursor to the **TRIG** zone, the following soft keys will be displayed:

INT
MA



N
EXT
DUT

- 2) Use above soft keys to set the trigger mode.

3.4.2 Auto level control function

Auto level control function can adjust the real test level (voltage across or current through DUT) to the test level value. This function can guarantee the test voltage or current being constant.

When using this function, the test level can be set within the range below:

The range of constant voltage: 10 mVrms to 1 Vrms

The range of constant current: 100 μ Arms to 10 mArms

NOTE: When the constant level function is valid, if the level exceeds above ranges, this function will be automatically set as OFF. The level value currently set is generally deemed as non-constant level value.

Operation steps for setting auto level control function

Execute the following steps and set the constant level function as ON or OFF.

- 1) Move the cursor to **ALC** zone, the following soft keys are displayed.

ON

OFF



- 2) Press **ON** to turn on the auto level control function.
- 3) Press **OFF** to turn off the auto level control function.

3.4.3 Bias current isolation function

Bias current isolation function can prevent the DC current from affecting the test input circuit. In **DCI ISO** zone, users can set the bias current isolation function as ON or OFF. When the bias current isolation function is set as ON, the bias current flowing through DUT can reach 100mA. When the bias current isolation function is set as OFF, the bias current value allowed to flow through DUT is shown as figure 3-1, if the bias current flowing through DUT is over the value in figure 3-1, then instrument cannot work normally.

Figure 3-1 Max. DC bias current

Test range	10 Ω	30 Ω	100 Ω	300 Ω	1 k Ω	3 k Ω	10 k Ω	30 Ω	100
									k Ω
Max.	2 mA	2 mA	2 mA	2 mA	1 mA	300	100	30 μ A	10 μ A
current						μ A	μ A		



Note: Bias current isolation function (ISO) can only be set as ON after installing bias board. After bias current isolation function is turned on, the test accuracy will be influenced, so under the condition of low frequency and bias current, the bias current isolation function should be set as OFF.

Operation steps for setting the bias current isolation function

(Bias board has been installed)

Execute the following steps and set the bias current isolation function as ON or OFF.

- 1) Move the cursor to **DCI ISO** zone, the following soft keys will be displayed.

ON
OFF

- 2) Press **ON** to turn on the bias current isolation function.
- 3) Press **OFF** to turn off the bias current isolation function.

3.4.4 Average

The AVERAGE function can calculate the average value of two or more test results.

The average times can be set from 1 to 255 with an increase or decrease of 1.

Operation steps for setting test average times.

- 1) Move the cursor to the **AVG** zone, the following soft keys are displayed.

INCR+

This key is used to increase the average times.

DECR-



This key is used to decrease the average times.

- 2) Use above soft keys to set the average times or use numeric keys and [ENTER] input average times directly.

3.4.5 Level monitor function

The level monitor function can monitor the real voltage across DUT or real current through DUT. The monitored voltage value is displayed in **V_m** zone on <MEAS DISPLAY> page while the monitored current value is in **I_m** zone.

Note: The correction function can influence the level monitor function, so when the correction data changes the level monitor value will change. When the correction is switched between OPEN or SHOR or LOAD, the level monitor value will be influenced as well

Operation steps for setting the level monitor function

Execute the following operation steps to set the level monitor function as ON or OFF.

- 1) Move the cursor to VAC MON zone, the following soft keys will be displayed.

ON

OFF

- 2) Press **ON** to set the voltage monitor function as ON while press **OFF** to set the voltage monitor function as OFF.

- 3) Move the cursor to IAC MON zone, the following soft keys will be displayed.

ON

OFF



- 4) Press **ON** to set the current level monitor function as ON while press **OFF** to set the current level monitor function as OFF.

3.4.6 Delay time

U2817A trigger delay means the delay time from triggering to test-start. Delay function can set the trigger delay time. When the list sweep test function is used, all set delay time will be delayed at each sweep test point. The range of the trigger delay time can be set from 0s to 60s with 1ms as the resolution. The trigger delay function is great useful when the instrument is applied in an auto test system. When the instrument is triggered by HANDLER interface, the trigger delay time can ensure DUT and test terminal has a reliable contact.

Operation steps for setting the delay function

Execute the following steps to set the measurement delay time.

- 1) Move the cursor to the **TRG DLY** zone.
- 2) the following soft keys are displayed.

INCR+

This key is used to increase the trigger delay times.

DECR-

This key is used to decrease the trigger delay times.

- 3) Use above soft keys to set the average times or Use numeric keys to input delay time. After pressing a numeric key, the following unit keys will be displayed. These soft keys can replace **[ENTER]** to input delay time.

mss



3.4.7 Output impedance

U2817A provides four output impedances for your choice: 100 Ω , 30 Ω and 10 Ω . When testing inductance, it is necessary to input the same output impedance so as to make data comparison with other instruments.

Note: When an optional bias board is selected, only 100 Ω is available. Operation steps for setting output resistance

Execute the following operations to set output impedance

- 1) Move the cursor to the **Rsou** zone, the following soft keys will be displayed.

100 Ω

30 Ω

10 Ω

- 2) Press **100 Ω** to select the output impedance as 100 Ω . Press **30 Ω** to select the output impedance as 30 Ω .

3.4.8 Deviation test function

The deviation test function can make the deviation value (instead of real test value) be directly displayed on the screen. The deviation value is equivalent to the real test value subtracting the pre-set reference value. This function brings great convenience to observe variations of component parameters with temperature, frequency, bias. Bias test function can be used for primary or secondary parameter or primary and secondary parameters meanwhile. The instrument provides two deviation test modes as below:

Δ ABS (Absolute Deviation mode)

The deviation currently displayed is the difference between the test value of the DUT and the preset reference value. The formula of calculating Δ ABS is as below:



$$\Delta\text{ABS}=\text{X}-\text{Y}$$

Where, X is the test value of DUT

Y is the preset reference value.

$\Delta\%$ (Percentage deviation mode)

The deviation currently displayed is the percentage of the difference between the test value of DUT and the preset reference value divided by the reference value. Its calculating formula is as below:

$$\Delta\%=(\text{X}-\text{Y})/\text{Y}*100[\%]$$

Where, X is the test value of DUT.

Y is the preset reference value.

Operation steps for setting deviation test function

- 1) Move the cursor to the **REF A** zone to input the reference value of the primary parameter, the following soft key will be displayed.

MEAS

When the reference component is connected with the test terminal, you should press **MEAS**. Then U2817A will test the reference component and the test result will be automatically input as the value of **REF A**.

- 2) Use **MEAS** or numeric keys to input the reference value of primary parameter.
- 3) Move the cursor to the **REF B** to input the reference value of the secondary



parameter, the following soft key will be displayed.

MEAS

When the reference component is connected to the test terminal, you should press **MEAS**. Then U2817A will test the reference component and the test result will be automatically input as the value of **REF B**.

- 4) Use MEAS or numeric keys to input the reference value of the secondary parameter. If the reference values of primary and secondary parameters have been set in steps 2), you can skip this step.
- 5) Move the cursor to the **DEV A** zone, the following soft keys will be displayed:

OFF

ΔABS

Δ%

- 6) Use above soft keys to set the deviation mode of the primary parameter.
- 7) Move the cursor to the **DEV B** zone, the following soft keys will be displayed.

OFF

ΔABS

Δ%

- 8) Use above soft keys to set the deviation mode of the secondary parameter.

3.4.9 BIAS SRC

Bias source is used to select the DC bias power. The instrument provides 3 kinds of bias source as shown below:

INT mode



The standard DC bias voltage source is from -10V to +10V and the DC bias current source is from 0 to 100mA.

NOTE: When the DC bias source is in use, only the output impedance of 100Ω can be used.

OPT mode

The optional DC bias source can provide internal DC bias current source (0~1A).

NOTE: 1A optional must be installed, then the mode can be supported.

EXT mode

When the instrument adopts the external bias source to perform on-line test, the EXT mode should be selected. We provide the following external bias source for your choice: U1773 and U1776.



NOTE: U1773 must be connected, then this mode can be supported.

Operation steps for setting bias source

- 1) Move the cursor to **BIAS SRC**, the following soft keys will be displayed.

OFF
INT
OP
T
EX
T

- 2) Press **OFF** to close the bias source.
- 3) Press **INT** to select the INT bias source.
- 4) Press **OPT** to select the OPT bias source.
- 5) Press **EXT** to select the EXT bias source.



3.5 <CORRECTION>

Press [MEAS SETUP] to select **CORRECTION** to enter into the <CORRECTION> page.

EUCOL 02:01:39 < Correction > TOOL	
OPEN : ON	SPOT No. : 0
SHORT : ON	SPOT FRQ: 1.00000kHz
LOAD : OFF	REF A: 0.00000pF B: 0.00000p
CABLE : 0m	OPEN A: ----- B: 0.00000pS
CH MODE: OFF	SHORT A: 0.00000pΩ B: 0.00000pΩ
FUNC : Cp-D	LOAD A: 0.00000pF B: 0.00000p
Info:Udisk is installed	
OFF	ON
	SPOT OPEN
	SPOT/DCR SHORT
	MEAS LOAD

Open, short and load correction on the <CORRECTION> page can be used to eliminate the distribution capacitance, spurious impedance and other measurement errors. U2817A provides two correction modes: the first one is executing open and short correction on all frequency points through interpolation method; the other one is executing open, short and load correction on the frequency point currently set. The following measurement control parameters can be set on the <Correction> page.

Open correction (**OPEN**)

Short correction (**SHORT**)

Load correction (**LOAD**)



Cable length selection (**CABLE**)

Single/ multiple correction mode selection (**CH MODE**)

Test function(**FUNC**)

Frequency points of OPEN, SHOR and LOAD (**SPOT NO.**, **SPOT FRQ**)

Reference values for every frequency points of load correction (**REF A**, **REF B**)

There are 12 zones on this page: **Correction**, **TOOL**, **Open**, **Short**, **Load**, **Cable**, **CH Mode**, **FUNC**, **SPOT NO.**, **SPOT FREQ**, **REF A**, **REF B**, Each control function zone will be introduced in the following paragraphs.

Besides above setting zones, the <CORRECTION> page will also display the following monitoring zones. The monitoring zones are similar with the setting zones, but the monitoring zones can only provide reference information and you cannot change state or parameter of these zones.

Real test results of the load correction (**LOAD A**, **LOAD B**)

The real test results of load correction can be tested on **SPOT FREQ**. Channels of the current multiple correction mode can be set through the multiple-channel sweep interface or IEEE 488 interface.

3.5.1 OPEN

The open correction function of U2817A can eliminate the error caused by the stray admittance (G, B) parallel-connected with DUT, shown as figure 3-1.

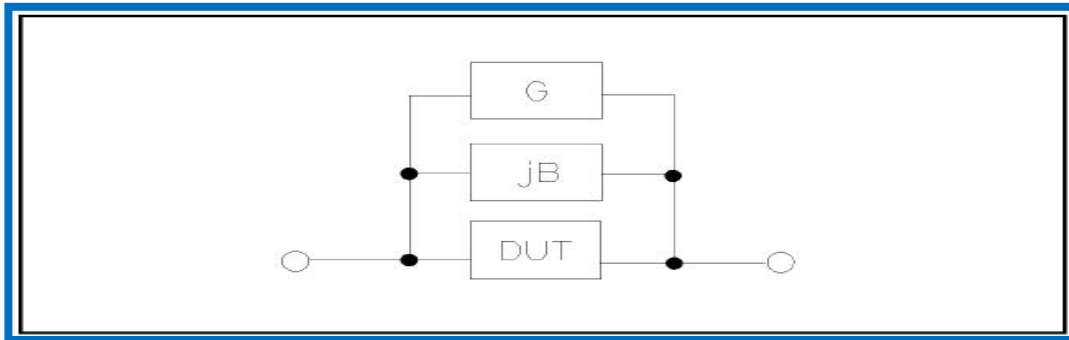

Figure 1 Stray Admittance

U2817A adopts the following two kinds of open correction data:

U2817A will automatically make open correction test on 48 fixed frequency points no matter what the currently set frequency is. Based on the open correction data of the following 48 frequencies, the instrument can calculate all open correction data of different test ranges which corresponds to all test frequencies. Move the cursor to **OPEN** and then used **SWEEP OPEN** to

execute full frequency open correction.

20 Hz	100 Hz	1 kHz	10 kHz	100 kHz
25 Hz	120 Hz	1.2 kHz	12 kHz	
30 Hz	150 Hz	1.5 kHz	15 kHz	
40 Hz	200 Hz	2 kHz	20 kHz	
50 Hz	250 Hz	2.5 kHz	25 kHz	
60 Hz	300 Hz	3 kHz	30 kHz	
80 Hz	400 Hz	4 kHz	40 kHz	
	500 Hz	5 kHz	50 kHz	



600 Hz	6 kHz	60 kHz
800 Hz	8 kHz	80 kHz

64 open correction frequencies can be set in SPOT NO. on <CORRECTION>.

Move the cursor to SPOT NO. and then use the INCR++, INCR+, DECR-, DECR-- soft key to set the 64 frequencies respectively.

Operation steps of open correction function

- 1) Move the cursor to OPEN, the following soft keys will be displayed:

ON

OFF

SWEEP

- 2) Connect test fixture to test terminal. The fixture is open and not connecting to any DUT.
- 3) Press SWEEP, U2817A will test the open admittance (capacitance and inductance) under 48 frequencies. It will take about 75 seconds to finish the open full-frequency correction. In the process of correction , the following soft key will be displayed:

CANCEL



This soft key can be used to terminate the current open correction operation and reserve the formal open correction data.

- 4) Press **ON** to turn on the function of open-circuit correction, then U2817A will perform open-circuit correction calculation in the later testing process. IF SPOT FREQ is set as OFF, the open-circuit correction data of the current frequency will be calculated by imbedding algorithm. When SPOT FREQ is set as ON, the value of the current test frequency will be that of SOPT FREQ, in this case, the open correction data of SPOT FREQ will be used to the calculation of open correction.
- 5) Press **OFF** to turn off the open correction function. In later measurement, no open correction calculation will be taken.

3.5.2 SHORT

The short correction function of U2817A can eliminate the error caused by spurious inductance (R, X) in serial with DUT as shown in figure 3-2.

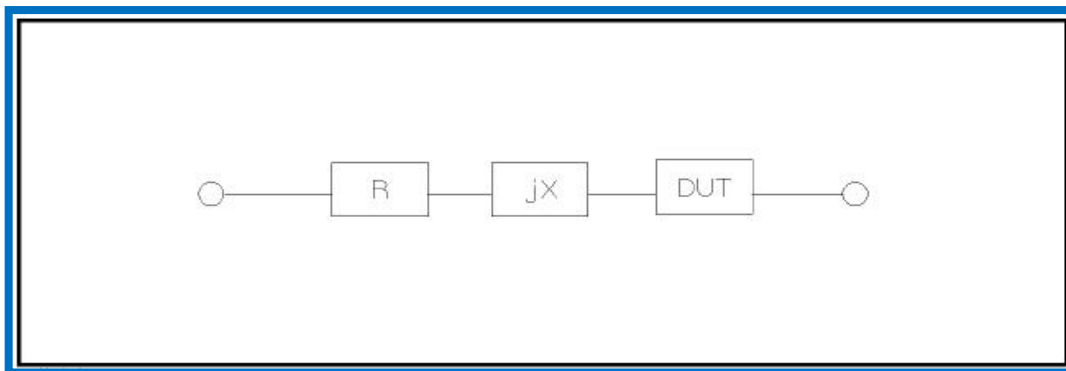

Figure 3-2 Spurious Inductance

U2817A adopts two kinds of short correction data.



No matter what the current frequency is, U2817A will execute short correction test on the 48 fixed frequency points. Except the 48 frequencies, the instrument will

adopt imbedding algorithm to calculate the short correction data of different test frequencies which correspond to different ranges. Move the cursor to the **SHORT** zone, and then use the **SWEEP SHORT** soft key to execute full frequency open correction. The 48 fixed frequencies are the same as that in open correction.

U2817A can set 64 short correction frequencies in the **SPOT NO.** zone on the <CORRECTION> page. Move the cursor to **SPOT FREQ** and then use **ON** to short correct the set frequencies.

Operation steps of short correction function

Short correction includes full frequency short correction which adopts imbedding algorithm and single frequency short correction on 64 frequencies. Execute the following operation steps to make short correction. The single frequency short correction can refer to “Load correction”.

- 1) Move the cursor to the **SHORT** zone, the following soft keys will be displayed:

ON

OFF

SWEEP SHORT

- 2) Connect the test fixture to the test ports. Short the test fixture by using short plate.
- 3) Press the **SWEEP SHORT** soft key, U2817A will test the short spurious impedances (resistance and reactance) of 48 frequencies. Short full frequency correction takes about 75 seconds and in this process, the following soft keys will be displayed.

CANCEL



This soft key can be used to cancel the current short correction operation and reserve the formal open correction data.

- 4) Press **ON** to validate the short correction function. U2817A will make short correction calculation in latter test. If SPOT FREQ is set as OFF, the short correction function will calculate the short correction data of the current frequency. If SPOT FREQ is set as ON and the current frequency is SPOT FREQ, the short correction data of SPOT FREQ will be used in the calculation of the short correction.
- 5) Press **OFF** to turn off the short correction function. In latter test, no short correction calculation will be performed.

3.5.3 LOAD

By using transport coefficient between the real test value and the standard reference value at the preset frequency (**SPOT NO.**), the load correction of U2817A can eliminate the test error. It is obvious that open, short, and load correction can be performed at preset frequencies. The 64 preset frequencies can be set in the setup zones of **SPOT NO.**. The standard reference values can be set in the setup zones of **REF A** and **REF B**. The standard test function must be set in the **FUNC** zone before setting

standard reference value. When the cursor moves to SPOT FREQ, the **MEAS LOAD** soft key will be displayed. Press **MEAS LOAD** to perform the load correction test.

Operation steps for setting load correction

According to the following steps, perform open/ short/ load correction test at preset frequencies.

- 1) Move the cursor to **SPOT NO.**, the following soft keys will be displayed:

INCR++



This is a coarse adjustment soft key used to increase series number of frequency.

INCR+

This is a fine adjustment soft key used to increase series number of frequency.

DECR-

This is a fine adjustment soft key used to decrease series number of frequency.

DECR--

This is a coarse adjustment soft key used to decrease series number of frequency.

- 2) Use soft keys or numeric keys to select or set frequency spot. When using numeric keys to input the required frequency spot, the soft key displays the available units (x1,ESC). You can use unit soft key or [ENTER] to input data.
- 3) Move the cursor to **SPOT FREQ**, the following soft keys will be displayed:

ON

Press this soft key to make the open/short/load correction data be available.

OFF

Press the soft key to make the open/short/load correction data be unavailable.

SPOT OPEN

Press this soft key to execute open correction at SPOT FREQ.

SPOT SHORT



Press this soft key to execute short correction at SPOT FREQ.

MEAS LOAD

Press this soft key to execute the load correction at SPOT FREQ.

- 4) Press the soft key **ON**, the original preset open/short/load correction frequency is displayed on the frequency setting zone.
- 5) Use numeric keys to input the correction frequency. After pressing any numeric key, the available unit keys (**Hz**, **kHz** and **MHz**) will be displayed on the soft key zone and these soft keys can replace the **[ENTER]** key to input correction frequency. When the **[ENTER]** key is used to input correction frequency, the default unit is Hz.
- 6) Connect the test fixture to the test terminal.

- 7) Make the test fixture be open.
- 8) Press **SPOT OPEN** to perform open correction at the current set frequency. The test result (G, B) of the open correction test will be displayed in the help line (the bottom line).
- 9) Move the cursor to **OPEN**.
- 10) Press **ON** to perform the open correction calculation at preset frequency in latter measurements.
- 11) Move the cursor to **SPOT FREQ** to set the required correction frequency.
- 12) Make the test fixture be short.
- 13) Press **SPOT SHORT** to perform short correction at preset frequency. The test result (R, X) of the short correction will be displayed in the help line (the bottom line).
- 14) Move the cursor to **SHORT**.



- 15) Press **ON** to perform the short correction calculation at preset frequency in latter measurements.
- 16) Prepare a standard test component.
- 17) Move the cursor to **FUNC.**
- 18) Set the function parameters required to be set.
- 19) Move the cursor to **REF A.**
- 20) Use numeric keys and unit keys to input the primary reference values of the standard component.
- 21) Move the cursor to **REF B.**
- 22) Use numeric keys and unit keys to input the secondary reference value of the standard component.
- 23) Move the cursor to the corresponding **SPOT FREQ.**
- 24) Connect the standard component to the test fixture.
- 25) Press **MEAS LOAD**, the instrument will execute a load correction. The real test results of the standard component will be displayed in **LOAD A** and **LOAD B.**
- 26) Move the cursor to **LOAD.**
- 27) Press **ON** to perform load correction calculation at preset frequencies in latter measurements.

3.5.4 Load correction test function

When performing load correction, the reference value of the standard component is required to be input in advance. The test parameters of reference value should conform with the preset load correction test function.



Load correction function adopts the transport coefficient between the real test value of preset frequency and the standard reference value to eliminate the test error. Load correction function is only available for calculating transport coefficient.

Operation steps for setting load correction test function Refer to section 3.1.1.

3.5.5 Cable length selection

The available cable length is 0m, 1m, 2m and 4m.

3.6 <LIMIT TABLE>

Press [MEAS SETUP] and then **LIMIT TABLE** to enter into the <LIMIT TABLE> page as the following figure shown.

EUCOL 00:25:11		< Limit Table >		TOOL
NOM : 1.00000nF	BIN	LOW		HIGH
FUN SWAP: Cp-D	1	-1.000 %		1.000 %
CMP MODE: TOL	2	-5.000 %		5.000 %
TOL MODE: %	3	-10.000 %		10.000 %
BIN CMP : OFF	4	-20.000 %		20.000 %
AUX BIN : OFF	5	-----		-----
PASS ALM: OFF	6	-----		-----
FAIL ALM: SHORT	7	-----		-----
	8	-----		-----
	9	-----		-----
	2nd	0.00000P		10.0000m
Info:Use softkeys to select				
ABS	%			



Compare function can be set on this page. U2817A can set 9 bin limits of primary parameters and one of secondary parameters. The tested result can be divided into up to 10 bins (BIN 1 to BIN 9 and BIN OUT). If the primary parameter of DUT is within the limit range from BIN1 to BIN9, but the secondary parameter is out of the limit range, in this case the DUT will be sorted into aux bin. When U2817A installs the HANDLER interface and it is used in automatic sorting system, the compare function will be especially useful. The following limit parameter of compare function only be set on <LIMIT TABLE> page.

Test parameter (**FUN SWAP**)

Limit mode of compare function (**CMP MODE**)

Nominal value (**NOM**)

Auxiliary bin ON/OFF (**AUX BIN**)

Compare function ON/OFF (**BIN CMP**)

Low limit of each bin (**LOW**)

High limit of each bin (**HIGH**)



3.6.1 Swap parameter

The swap parameter function can swap the primary and the secondary parameter in **FUN SWAP**. For example, when the test parameter is Cp-D, the swap parameter function can change the test parameter as D-Cp. Then user can set 9 pairs of compare limits for D, but only 1 pair of compare limit can be set for Cp.

Operation steps for the swap parameter function

Execute the following operations to swap the primary and the secondary parameters.

- 1) Move the cursor to **FUN SWAP**, the following soft key will be displayed.
SWAP
- 2) Press **SWAP** to swap the primary and the secondary parameters.
- 3) Press **SWAP** to swap the primary and the secondary parameter, which is to recover the formal setup.

3.6.2 Limit modes of compare function

Compare functions has two limit setup modes for primary parameters as shown in figure 3-3.

Tolerance mode

Under tolerance mode, set the deviation value of the nominal one (be set in the **NOM** zone) as the compare limit value. Deviation value has two modes: percentage deviation and absolute deviation.

Sequential mode

Under sequential mode, the range of the test value is the compare limit value.

The compare limit value should be set in the order from small to large.

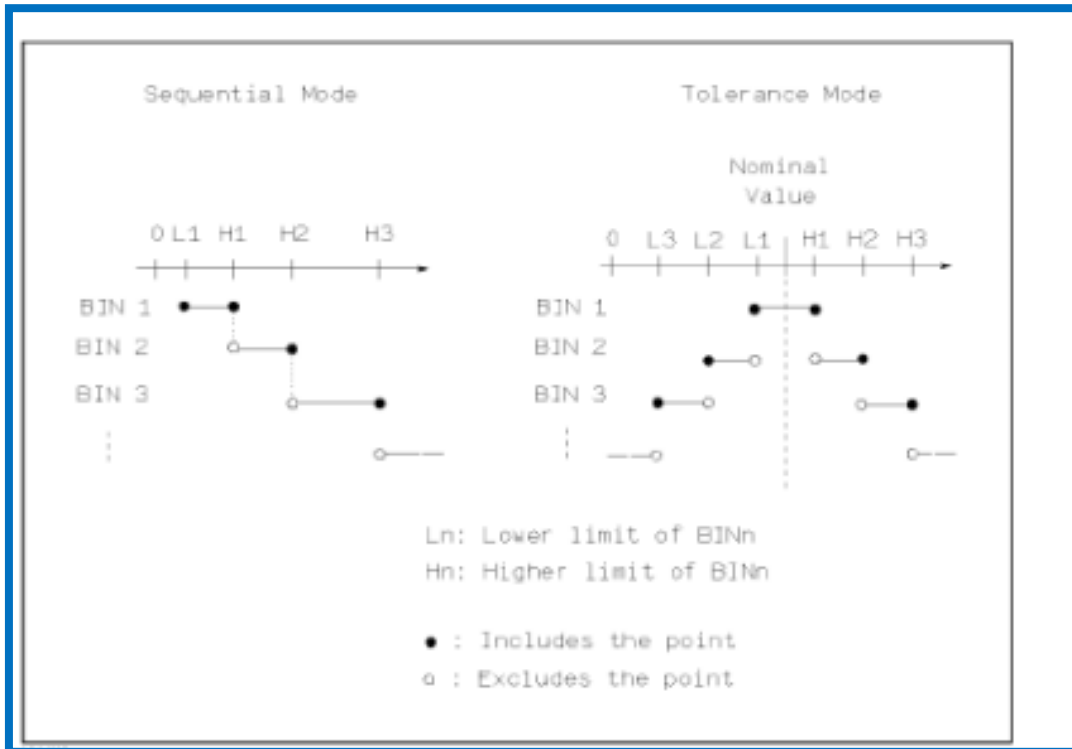

Figure 3-3 Tolerance mode and Sequential mode

Note: When setting limit values of tolerance mode, the error range should be set in the order from small to large. If the error range of BIN1 is the largest one, then all DUT will sort into BIN 1.

Under tolerance mode, the low limit is not necessary to be smaller than the nominal value and the high limit is not necessary to be larger than the nominal value. The limit range of each bin can be discontinues or overlapped.



Operation steps for setting the limit mode of the compare function

- 1) Move the cursor to the **CMP MODE** zone, the following soft keys will be displayed.

TOL

This soft key is used to set the limit mode as the tolerance mode

SEQ MODE

This soft key is used to set the limit mode as sequential mode.

- 2) Use above soft keys to set the limit mode.

3.6.3 Set nominal value of tolerance mode

When the tolerance mode is selected as the limit mode of the primary parameter, it is necessary to set the nominal value. The nominal value can be any one within the display range.

When the sequential mode is selected as the limit mode the primary parameter, the nominal value can be set, but it is not necessary to use it under this mode.

Operation steps for setting the nominal value



- 1) Move the cursor to **NOM**.
- 2) Use numeric keys to input nominal value. After inputting the data, the following soft keys (**p, n, u, m, k, M, *1**) can replace the [ENTER] key to input the nominal value. When using [ENTER] to input the nominal value, the default unit is the same as that input last time. Press ***1** to input nominal value, the instrument will select F, H or Ω as the default unit of the nominal value according to primary parameter.

3.6.4 Comparator function ON/OFF

U2817A can set 9 bin limits of primary parameters and 1 bin limit of secondary parameters. The tested results can be sorted into 10 bins (BIN 1 to BIN 9 and BIN OUT) at most. If the primary parameter of DUT is within the limit range from BIN 1 to BIN 9, but the secondary parameter is out of the limit range, in this case the DUT will be sorted into aux bin. When U2817A installs the HANDLER interface and it is used in the automatic sorting system, the compare function will be especially useful.

Operation steps for setting the compare function ON/OFF

- 1) Move the cursor to **COMP**, the following soft keys will be displayed.

ON
OFF

- 2) Use above soft keys to set the compare function as ON or OFF.

3.6.5 Auxiliary bin ON/OFF

When it is necessary to sort the secondary parameters, the limits of the secondary parameter can be set in **HIGH** and **LOW** of 2nd.

Three cases may occur in the process of secondary parameter sorting:

On <LIMIT TABLE > page, no low / high limit of the secondary parameters has been set.



On < **LIMIT TABLE** > page, the low/high limit of secondary parameters has

been set but **AUX BIN** function is set as OFF.

In this case, only those components whose secondary parameters are qualified can perform primary parameter sorting according to sorting limits. If the secondary parameters are unqualified and the corresponding primary parameters are within limit ranges, those components will be sorted into BIN OUT.

On <**LIMIT TABLE**> page, the low/high limit of the secondary parameters has been set and the **AUX BIN** function is set as ON.

If the primary parameter is out of the limit range, it is sorted into BIN OUT. If the primary parameter of DUT is within the limit range but its secondary parameter is out of the limit range, the DUT will be sorted into the **AUX BIN** bin.

Note: When the secondary parameter only has low limit and the auxiliary bin is set as ON, if the primary parameter of DUT is within the limit range and the secondary parameter is smaller than or equal to its low limit, the DUT will be sorted into the auxiliary bin. When the secondary parameter only has high limit and the auxiliary bin is set as ON, if the primary parameter of DUT is within the limit range and the secondary parameter is larger than or equal to its high limit, the DUT will be sorted into the auxiliary bin.

Operation steps for setting the auxiliary bin function ON/OFF

- 1) Move the cursor to **AUX BIN**, the following soft keys will be displayed.



ON

OFF

- 2) Use above soft keys to set the auxiliary function as ON or OFF.

3.6.6 HIGH/LOW

U2817A can set bin limits of 9 primary parameters and one secondary parameter. The test results can be sorted into 10 bins at most (BIN 1 to BIN 9 and BIN OUT). The high/low limits of primary parameters can be set in high limit and low limit of bins from BIN 1 to BIN 9. The limit of the secondary parameter can be set in **HIGH** and **LOW** of 2nd.

Operation steps for setting high/low limit Execute the following steps to set sorting limits.

- 1) Set **FUN SWAP** and **NOM** in the compare function menu and the limit **CMP MODE** and **TOL MODE** of the primary parameter.
- 2) Move the cursor to Low limit of BIN 1. If you select tolerance mode, the following operation steps should be from step 3 to step 6; if you select sequential mode, the following operation steps should be from step 7 to step 11.
- 3) User numeric keys to input low limit value in Low limit. After inputting the data, you can use (**p**, **n**, **μ**, **m**, **k**, **M**, ***1**) to replace **[ENTER]** to input the limit value. When **[ENTER]** is used, the default unit is the same as that being input last time. When pressing ***1**, the default unit will be F, H or Ω. After inputting limit value in **LOW** of BIN 1, the low limit of BIN 1 will be automatically set as – (absolute limit) and the high limit will be + (absolute limit).
- 4) The cursor will automatically move to **LOW** of BIN 2. Repeat step 3 until the limits of BIN 9 are input. Then the cursor will automatically move **LOW** of 2nd.



- 5) After inputting the low limit of the secondary parameter, the cursor will automatically move to **HIGH** of 2nd.
- 6) Input the high limit of the secondary parameter.
- 7) In Low limit of BIN 1, use numeric keys to input the low limit. After inputting the data, you can use (**p, n, u, m, k, M, *1**) to replace **[ENTER]** to input the limit value. When **[ENTER]** is used to input the limit value, the default unit is the same as that being input last time. When pressing ***1**, the default unit will be F, H or Ω .
- 8) After inputting the low limit of BIN 1, the cursor will automatically move to **HIGH** of BIN 1. Input the high limit of BIN 1.
- 9) The cursor will automatically move **HIGH** of BIN 2. For the limit mode is sequential mode, the low limit of BIN 2 will be the high limit of BIN 1. Input the high limit of BIN 2.
- 10) Repeat step 9 until the high limit of BIN 9 is input. Then the cursor will automatically move to **LOW** of 2nd. Input the low limit of the secondary parameter.
- 11) The cursor will automatically move to **HIGH** of 2nd. Input the high limit of the secondary parameter.



3.7 <LIST SETUP>

Press [MEAS SETUP] and then **LIST SETUP** to enter into the <LIST SETUP> page as shown below.

EUCOL		02:02:51		< List Setup >			Option	
No.	FUN	FREQ[Hz]	LEV[V]	BIAS[x]	STP.DLY	LMT:LOW	LMT:HIGH	
0	Cs	1.0000k	1.0000	----	0ms	0.0000pF	0.0000pF	
1	D	10.0000k	1.0000	----	0ms	0.0000p	0.0000p	
2	Z	1.0000k	1.0000	----	0ms	0.0000pΩ	0.0000pΩ	
3	Z	10.0000k	1.0000	----	0ms	0.0000pΩ	0.0000pΩ	
4	OFF	-----	-----	-----	-----	-----	-----	
5	OFF	-----	-----	-----	-----	-----	-----	
6	OFF	-----	-----	-----	-----	-----	-----	
7	OFF	-----	-----	-----	-----	-----	-----	
8	OFF	-----	-----	-----	-----	-----	-----	
9	OFF	-----	-----	-----	-----	-----	-----	
Info:Use softkeys to select								
Meas Setup		Correc tion		Limit Table		List Setup		Graph Setup



The list sweep function of U2817A can perform auto sweep test for the test frequency, test level or bias voltage of 10 points. On <LIST SETUP> page, the following list sweep parameters can be set.

Sweep mode (**Mode**)

Sweep parameter setup (frequency [**Hz**], level [**V**], level [**I**], bias [**V**], bias [**I**])

Sweep test point setup (sweep point)

High/low limit (**HIGH**, **LOW**)

3.7.1 MODE

Mode menu is the same as the mode on <List sweep> page.

3.7.2 Test parameter

Sweep parameters can be: frequency [Hz], level [V], level [I], bias [V], bias [I].

Operation steps for setting test parameter

- 1) Move the cursor the line following **FREQ**; the following soft keys will be displayed.

DEFAULT

- 2) Use above soft key to set the frequency as 1kHz.

- 3) Move the cursor the line following **LEV[V]**; the following soft keys will be displayed.

LEVEL(V)

LEVEL(A)

- 4) Use above soft keys to set the level as voltage mode or current mode.



- 5) Move the cursor the line following **BIAS[V]**; the following soft keys will be displayed.

BIAS(V)

BIAS(A)

CLOSE

- 6) Use above soft keys to set the bias as voltage mode, current mode or close.

3.7.3 Sweep parameter setup

Move the cursor to the table to perform the setup of each sweep parameter: **FUN**, **FREQ** (**HZ**), **LEVLE**, **BIAS**, **HIGH** and **LOW**. Use numeric keys on the front panel to input the data of test parameter/frequency/level/bias and high/low limit used to compare. After setting, if some inputs are unnecessary, you can execute the function of “Clear Table” in the soft key zone to delete the corresponding value.

Operation steps for clear table

- 1) Move the cursor the line following **OPTION**; the following soft keys will be displayed.

MODE SEQ

STP FAIL CONT

CLEAR TABLE

- 2) Use **CLEAR TABLE** soft key to delete the all values in table.



Chapter 4 [SYSTEM] and <FILE>

4.1 <SYSTEM>

Press [System] to enter into the <SYSTEM SETUP> page shown as below.

EUCOL	02:03:33	< System Setup >	TOOL	
SKIN	: GRAY	HDL TRIG	EDGE: RISE	
LANGUAGE	: ENGLISH	HDL OUTPUT	: HOLD	
PASS ALARM	: OFF	HDL DELAY	: 0ms	
FAIL ALARM	: SHORT	BUS MODE	: RS232C	
KEY SOUND	: ON	BUS ADDR	: 8	
PASSWORD	: OFF	BAUD RATE	: 9600	
SAVE TYPE	: GIF	MULTI MODE	: OFF	
TIME	: 2010-01-01 02:03:33	FETCH MODE	: QUERY	
Info: Use softkeys to select				
System Setup		System Info	Firmware Update	System Test

On this page, most system setup items are displayed, such as instrument skin, language, PASS alarm, FAIL alarm, password, bus mode, GPIB address, baud rate, data/time.

4.1.1 SKIN

The function of this zone is to set the theme of display.

Operation steps for setting the theme of display

- 1) Move the cursor to SKIN, the following soft keys will be displayed.

GRAY
BLAC
K
BLUE



- 2) Use above soft keys to select the theme of display.

4.1.2 LANGUAGE

This zone is used to control and display the current language mode of the operating instrument.

Operation steps for setting language

- 1) Move the cursor to Language, the following soft keys will be displayed.

English

This soft key is used to select English as the operation language.

中文

This soft key is used to select Chinese as the operation language.

4.1.3 PASS ALARM

This zone is used to control and display the beep mode when the test result is qualified.

Operation steps for setting PASS ALARM

- 1) Move the cursor to PASS ALARM, the following soft keys will be displayed.

OFF

This soft key is used to set the pass beep function OFF.

LONG

This soft key is used to select long beep.

SHORT

This soft key is used to select short beep.

TWO SHT



This soft key is used to select two low and short beeps.

LED ON

This soft key is used to select LED light on.

4.1.4 FAIL ALARM

This zone is used to control and display the beep mode as **FAIL ALARM** when the test result is unqualified.

Operation steps for setting FAIL ALARM

- 1) Move the cursor to FAIL ALARM, the following soft keys will be displayed.

OFF

This soft key is used to set the fail beep function OFF.

LONG

This soft key is used to select long beep.

SHORT

This soft key is used to select short beep.

TWO SHT

This soft key is used to select two low and short beeps.

LED ON

This soft key is used to select LED light on.

4.1.5 KEY SOUND

Operation steps for setting key sound

- 1) Move the cursor to KEY SOUND, the following soft keys will be displayed.

OFF



ON

- 2) Use above soft keys to turn OFF/ON the key sound.

4.1.6 PASSWORD

This zone is used to display the password –protection mode.

Operation steps for setting the password

- 1) Move the cursor to Password, the following soft keys will be displayed.

OFF

This soft key is used to turn off the password protection mode.

KEYLOCK

This soft key is used to protect unlock keyboard.

Hold SYSTEM

This soft key is used to turn on the password protection function including file protection and starting up password.

Hold FILE

This soft key is used to protect user's file.

MODIFY

This soft key is used to modify the password. The operation steps are as follows:



Press **MODIFY** to input a new password. After inputting, a prompt information will appear on the screen to prompt you to confirm the new password. Input the new password again till the modification finishes.

Note: The default password is 123456.

4.1.7 SAVE TYPE

Operation steps for setting the type of files

- 1) Move the cursor to **SAVE TYPE**, the following soft keys will be displayed.

CSV
TXT
GIF
BMP8
BMP24
PNG

- 2) Use above soft keys to select the type of files.

4.1.8 BUS MODE

This mode is used to select RS232C, USBTMC or USBCDC.



Operation steps for setting bus mode

- 1) Move the cursor to **BUS MODE**, the following soft keys will be displayed.

RS232CUSBTMC USBCDC

- 2) Use above soft keys to select the required interface bus.

Note: GPIB optional must be installed before GPIB mode is available.

4.1.9 GPIB ADDR (Reserved function)

This zone is used to control and display the current GPIB address.

Operation steps for setting GPIB address:

- 1) Move the cursor to **BUS ADDR**, the following soft keys will be displayed.

INCR+

This soft key is used to increase the GPIB address.

DECR-

This soft key is used to decrease the GPIB address.

4.1.10 BAUD RATE

Baud rate is used select the baud rate of the RS232C interface. The available baud rate of this instrument is from 4.800k to 115.200k.

Operation steps for setting the baud rate

- 1) Move the cursor to **BAUD RATE**, the following soft keys will be displayed.



4800
 9600
 19200
 38400
 57600
 115200

2) Use above soft key is to set the baud rate.

4.1.11 DATA/TIME

When moving to the time zone, user should input the password to enter.

4.1.12 SYSTEM INFORMATION

Press **SYSTEM INFO** enter into the <SYSTEM INFO> page shown as below.

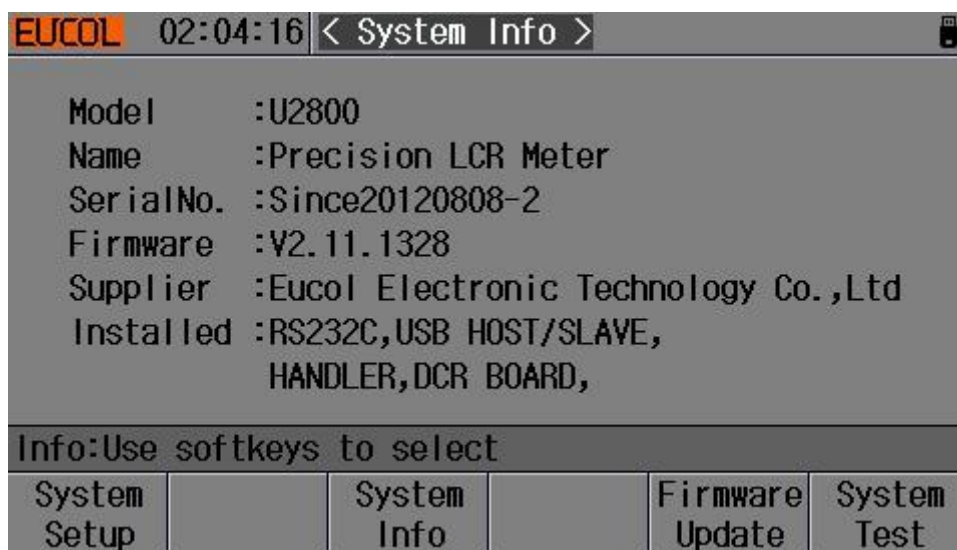



4.1.13 FIRMWARE UPDATE

- 1) Press **FIRMWARE UPDTE** enter into the <FIRMWARE UPDATE> page shown as below.

EUCOL	16:24:12	< Firmware Update >		
No.	NAME (SIZE)	DATE		
1	. 88026_4P (339kB)	2013-06-06 14:37		
2	. 88027_4P (340kB)	2013-06-06 14:08		
3	. U18_S212 (344kB)	2013-06-19 09:16		
4	. U2816A (343kB)	2013-06-06 14:46		
5	. U2816B (339kB)	2013-06-06 14:41		
6	. U2817A (340kB)	2013-06-06 14:42		
7	. U16_V212 (343kB)	2013-06-19 09:07		
8	. LD2817A (340kB)	2013-06-20 12:00		
9	. U2817_MY (341kB)	2013-06-22 16:03		
10	. U2815 (335kB)	2013-06-25 12:17		
Info:Use softkeys to select			Memory:UDisk	
UPDATE				EXIT



2) Press **UPDTE**, the following soft keys will be displayed.

YES

NO

3) Press **YES** soft key to update the firmware of the instrument.

4.1.14 SYSTEM TEST

Press **SYSTEM TEST** enter into the <SYSTEM TEST> page shown as below.

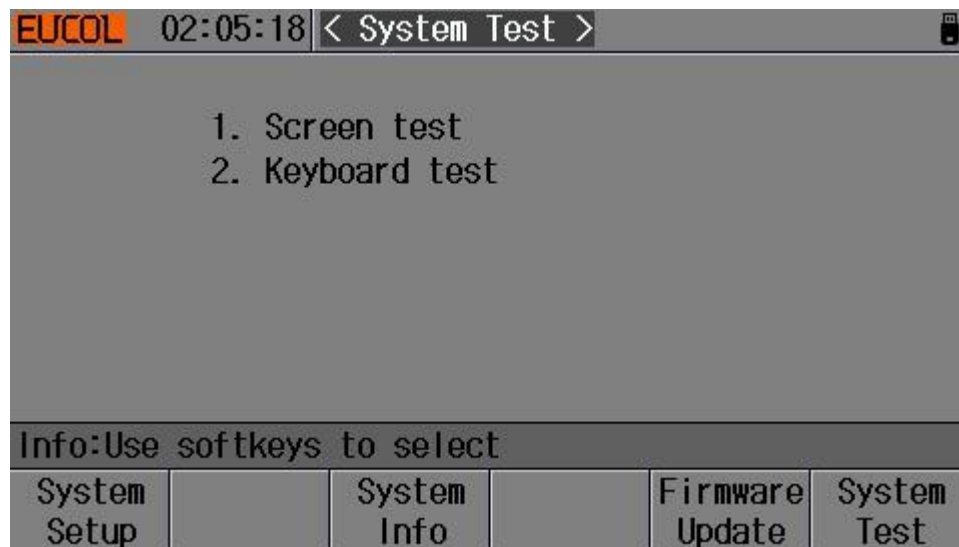



4.2 <FILE>

U2817A instrument can save the user-set parameter to the nonvolatile memory in the form of file, so when use the same setting next time user can load a corresponding file to obtain the parameter set and used last time. By doing so, it can save the time of setting parameter and improve the production efficiency. The file manage function of the transformer scanning will be described in the part of transformer test setting.

Press [FILE] to enter into the file manage page, shown as below.

EUCOL		02:06:49	< File List >		
No.	NAME	DATE			
1	A56	2010-01-01 02:06			
2	.				
3	.				
4	.				
5	.				
6	.				
7	.				
8	.				
9	.				
10	.				
Info:Use softkeys or input data			Memory:ROM		
LOAD	SAVE	DELETE	COPY	RENAME	EXIT



4.2.1 Setup file for single-group component (*.EST)

100 groups of different single groups of component set file (*.EST) can be saved in the instrument, but the *.EST file with the number more than 100 should be saved in external U-disk.

Use **FILE** function on the following File menus, the following data will be saved or loaded in the form of file, which are called *.EST file.

Control and setting parameter on <MEAS SETUP> page

- FUNCA
- FUNCB
- FREQ
- LEVEL
- RANGE
- SPEED
- DC BIAS
- BIAS SRC
- TRIGG
- ALC
- DELAY
- Rsou
- AVG
- Vm
- Im
- ISO
- DEV A
- DEV B



REF A

REF B

Control and set parameters on <BIN DISP> page

BIN COUNT (ON/OFF)

Control and set parameter on <LIMIT SETUP> page

PARAM (swap parameter)

NOM

MODE (%-TOL/ABS-TOL/SEQ-MODE)

AUX (ON/OFF)

COM (ON/OFF)

High and low limits of each bin

Control and set parameters on <List Setup> page

List Sweep Mode (SEQ/STEP)

List Sweep Parameter (Frequency/Level/Bias)

Test points of all sweep parameters

High and low limits of all test points, including limit parameters (LIMIT-DATA A/LIMIT-DATA B)

4.2.2 U-disk manage performance

As described above, U2817A has a standard configuration of USB HOST interface, so the external U-disk can be used as the memory media. In this condition, it breaks the memory limit of 100 groups of *.EST files. Meanwhile those files can be copied to IBM PC or compatible desk-top computer, laptop with USB interface to reach the infinite extension.

U2817A supports the USB memory devices as below:



Meet the USB 1.0/1.1 standard

Capacity: 32MB/64MB/128MB/256MB

File format: FAT32(Format the USB memory on Microsoft Windows operation system)

4.2.3 Operation steps for file management

A. Save the following control and setting parameters to a file by the following steps

- 1) Select and set all control and setting parameters on the desired page.
- 2) Press [FILE], the following soft keys will be displayed.

LOAD

SAVE

DELET

E

COPY

RENAM

E EXIT

- 3) In the file list, move the cursor to the file-saved position or input the file number directly.
- 4) Press **SAVE**, the following soft keys and “File name: ”will be displayed.

ESC

- 5) Press **ESC** to cancel the current save operation and return step 2.
- 6) Use numeric keys to input the current file name and press [ENTER]. Then U2817A will save the control and setting parameters as a file in this name.

B. Load the control and setting parameters from a file by the following steps

- 1) Press [FILE], the file list and the following soft keys will be displayed.



LOAD

SAVE

DELETE

COPY

RENAME

EXIT

- 2) In the file list, move the cursor to the file-saved position or input the file number directly.
- 3) Press **LOAD**, the following soft keys will be displayed.

Yes

No

- 4) Press **No** to cancel the current load operation and return step 1.
- 5) Press **Yes** to load the currently selected file. Then U2817A will return the current display page.

C. Copy a file to an U disk by the following steps

- 1) Assuming that it is necessary to copy internal files 2 and 3 to files 12 and 13 respectively.
- 2) Press [**FILE**], the file list and the following soft keys will be displayed.

LOAD

SAVE

DELETE

COPY

RENAME

EXIT

- 3) Press **COPY** soft key, the help information display "Input source file's No."
- 4) Using numeric keys to input the source file's position, press [**ENTER**], the help information display "Input destination file's No."
- 5) Using numeric keys to input the destination file's position, press [**ENTER**], the help information display "Input file's nums."



- 6) Using numeric keys to input the number of files, press [ENTER], the files are copied to the position.
- 7) If the input file number is larger than the maximum memory number (100 groups of file setting), the instrument will automatically read and write file in U-disk automatically. You have to insert a U-disk to the USB interface, UDISK OK! will be displayed in the file status zone.

NOTE: Please make sure that your U-disk meets the standard that described in this chapter and no write-read protection.

Chapter 5 Execute LCR operation and some examples

5.1 Correction operation

To execute correction operation (in order to prevent the stray impedance from affecting the test accuracy, it is necessary to make open/short correction), users can select one of the two correction modes.

5.1.1 Sweep correction

- a) Press the menu key [MEAS SETUP] and then the soft key **CORRECTION**, the instrument will enter into the < **CORRECTION** > page.
- b) Move the cursor to the **OPEN** zone. **ON**, **OFF** and **SWEEP OPEN** will be displayed in the soft key zone.
- c) Keep the test fixture be in the open status, then press **SWEEP OPEN** to execute open correction till the prompt information zone displays that open correction is finished.
- d) Press **ON** to turn on the open correction function.
- e) Insert the short plate (U26010) to the test fixture.
- f) Move the cursor to the **Short** zone. **ON**, **OFF** and **SWEEP SHORT** will be displayed in the soft key zone.
- g) Press **SWEEP SHORT** to execute the short correction till the prompt information zone displays that the short correction is finished.



- h) Press **ON** to turn the short correction function.
- i) Move the cursor to the **LOAD** zone. **ON**, **OFF** will be displayed in the soft key zone.
- j) Press **OFF** to turn off the load correction function.
- k) Move the cursor to the **SPOT NO.** zone, using numeric key to set **SPOT NO.** as “SPOT NO.:0” .
- l) Move the cursor to the **SPOT FREQ** zone, **ON**, **OFF**, **SPOT OPEN**, **SPOT SHORT** and **MEAS LOAD** will be displayed in the soft key zone.
- m) Press **OFF** to turn off the point-frequency correction function of **SPOT NO.:0**.
- n) Repeat step **k)** to **m)** to turn off all of the point-frequency correction function.

5.1.2 Point-frequency correction

This function will gain better results in single-frequency test.

If the test frequency is 5.5kHz,

- a) Press the menu key [**MEAS SETUP**] and then **CORRECTION**, then instrument will display the <**CORRECTION**> function.
- b) Move the cursor to the **Open** zone, **ON**, **OFF** and **SWEEP OPEN** will be displayed in the soft key zone.
- c) Press **ON** to turn on the open correction function.
- d) Move the cursor to the **Short** zone, **ON**, **OFF** and **SWEEP SHORT** will be displayed in the soft key zone.
- e) Press **ON** to turn on the short correction function.
- f) Move the cursor to the **LOAD** zone, **ON**, **OFF** will be displayed in the soft key zone.
- g) Press **OFF** to turn on the load correction function.
- h) Move the cursor to the **SPOT FREQ** zone, **ON**, **OFF**, **SPOT OPEN**, **SPOT SHORT** and **MEAS LOAD** will be displayed in the soft key zone.
- i) Press **ON** to turn on the point-frequency correction function of **SPOT FREQ**.



- j) Press [5] [.] [5], +5.5 will be displayed in the prompt information zone at the bottom of the screen meanwhile the available units (**Hz**, **kHz** and **MHz**) will be displayed in the soft key zone. Press **kHz**, the **SPOT FREQ** zone will be changed as 5.5000kHz (be the same as that of test frequency).
- k) Keep the test fixture be in open status and press **SPOT OPEN** to execute open correction.
- l) Insert the short plate (U26010) to the test fixture.
- m) Press **SPOT SHORT** to execute short correction.

5.2 Correct connection of DUT

There are 4 pairs of test terminal: Hcur, Hpot, Lpot and corresponding shielding terminal of each terminal.

Each terminal contains shielding layer whose function is to reduce the influence of the ground stray capacitance and the interference of the electromagnetic field. In the process of testing, Hcur, Hpot and Lpot, Lcur should be connected with DUT lead to form a complete 4-terminal measurement, thus reducing the effect of the lead and the connection points on the test results (especially the dissipation measurement). When testing low-ohm components, Hpot, Lpot should be connected to the lead terminal so as to avoid the impedance being added to the lead impedance and the connection principle is that the Hpot and Lpot test should be the actual existed voltage on DUT.

In other words, before connecting to DUT, it is not recommended to connect Hcur, Hpot with Lpot, Lcur, for doing this will increase test error.

If the connection point and the lead resistance R lead are far weaker than the tested impedance (for example: $R_{lead} < Z_x / 1000$, the accuracy error is required to be less than 0.1%), before connecting to DUT, it is recommended to connect Hcur, Hpot and Lpot, Lcur (Two terminal test).

In the test with high accuracy requirement, using Kelvin test fixture (standard accessory) will gain better results than using test leads. When Kelvin test lead is used under 10kHz, a better measurement result can be obtained.

However, when the frequency is higher than 10kHz, it cannot meet the measurement demand. In high frequency, the change of the clearance between test leads will directly



change stray capacitance and inductance on test terminals and this problem is unavoidable, because the test leads cannot be fixed in a position.

So, the use of the test fixture should be used as possible in high frequency. If the test fixture is unavailable or cannot be used, the status of test leads should be the same in the processes of correction and test.

No matter the standard Kelvin test fixture or Kelvin test leads or user-made fixture is used, the following requirements should be met.

1. Distribution impedance must be reduced to the Min. especially when testing high impedance components.
2. Contact resistance must be reduced to Min.
3. Short and open must be available between contact points. Open and short correction can easily reduce the influence of distribution impedance of the test fixture on measurement. For open correction, the clearance between test terminals should be the same with that when they connects with DUT. For short correction, the short plate of low impedance should be connected between test terminals. Another way is to directly connect Hc with Lc or Hp with Lp, then connect both.

Note: When the DUT is a polarity component, before testing, the high potential terminal should be connected to the terminal with mark “+”, “Hc” or “Hp” and the low terminal should be connected to the terminal with mark “-”, “Lc” or “Lp”.

Warning: Before testing, please discharge the tested polarity component so as to avoid the damage to the instrument.

5.3 Eliminate the influence of stray impedance

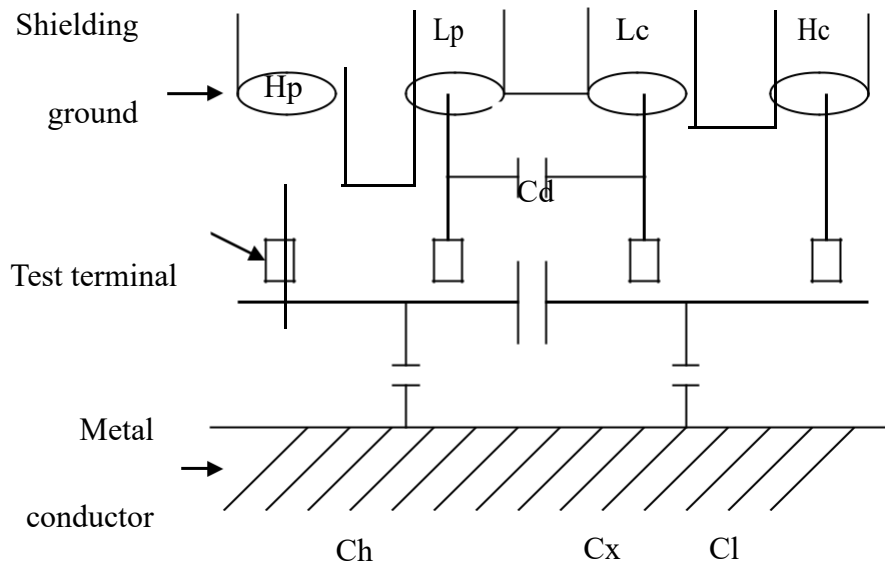

Figure 5-1 Influence of stray capacitance

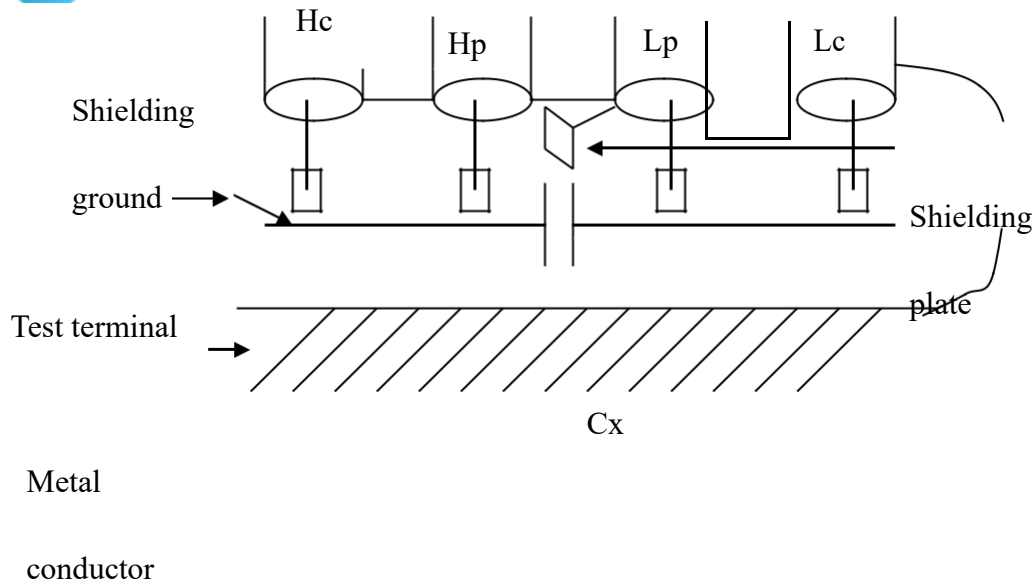

Figure 5-2 Eliminate the influence of stray capacitance

When the DUT has high impedance (such as small capacitance), the influence of stray capacitance cannot be ignored. Figure 5-1 is an example of the use of 4 terminal pair measurement. In this figure, C_d is connected with C_x in a parallel way and when a conductance plate is positioned under DUT, capacitance C_h will connect with C_x in parallel after connecting with C_l in series and by this way the measurement result will have errors. If a ground conductor is installed between high and low terminals, C_d can be reduced to Min. Meanwhile if the ground terminal is connected to the conductance plate, the influence of C_h and C_l will be eliminated. When the DUT is low impedance (such as small inductance, large capacitance), a large current will flow through test leads H_c and L_c . In this case, **electromagnetic coupling between test leads becomes the main source of test errors** except the influence of the contact resistance on test terminals. If this coupling cannot be eliminated, it will bring unexpected influence on test results. Generally, contact resistance affects the resistance of impedance and electromagnetic affects the reactance of impedance. Test terminals can adopt 4TP connection method. For 4TP connection, the currents flow though H_c and L_c are equal in value and opposite in direction with those flowing through each shielding terminals. By this way, the magnetic fields produced by these currents can be mutually offset and further eliminate the influence of mutual inductance coupling on test results.

5.4 Operation example for testing inductance with U2817A

Test Condition

Function: Ls-Q

Frequency: 5.5kHz



Level: 1.5Vrms

Internal impedance: 100Ω



Operation steps

- 1) Turn on the instrument.
- 2) Set basic parameters
 - a) Press [MEAS DISP] to enter into the <MEAS DISPLAY> page.
 - b) Move the cursor to **FUNC A-B** zone, the current item is displayed as Cp-D.
 - c) Press the soft key **MORE**, **Cs-D**, **Cs-Q** and **Cs-Rs** will be displayed.
 - d) Press the soft key **MORE**, **Lp-D**, **Lp-Q**, **Lp-G** and **Lp-Rp** will be displayed.
 - e) Press the soft key **MORE**, **Ls-D**, **Ls-Q** and **Ls-Rs** will be displayed.
 - f) Press **Ls-Q** to select the Ls-Q function.
 - g) Move the cursor to **FREQ**, the current frequency is 1.0000kHz.
 - h) Press [5][.][5], +5.5 will be displayed in the prompt information zone at the bottom of the screen. The available units **Hz**, **kHz** and **MHz** will be displayed in the soft key zone. Press **kHz**, the frequency will be changed as 5.5000kHz.
 - i) Move the cursor to **LEVEL** zone, the current displayed level will be 1.000V.
 - j) Press [1][.][5], +1.5 will be displayed in the prompt information zone at the bottom of the screen. The available units mV, V, μ A, mA and A will be displayed in the soft key zone. Press [ENTER], the level will be changed as 1.5V.
 - k) Press [MEAS SETUP] to enter into the <MEAS SETUP> page.
 - l) Move the cursor to **SRC IMP** zone, **30 Ω** , **100 Ω** , **10 Ω /CC** and **50 Ω** will be displayed in the soft key zone.
 - m) Press **100 Ω** to select 100 Ω as the signal internal impedance.
- 3) Connect the test fixture (U26005) to the test terminals of U2817A.
- 4) Execute correction (To avoid the influence of stray impedance on measurement accuracy, Open/ Short correction must be operated) (refer to 5.1.2 “Point-frequency correction”)
- 5) Mount the tested inductance to the test fixture.



6) Execute test operation.

Press [MEAS DISP] to enter into the <MEAS DISPLAY> page.

The instrument can test continuously and the test result will be displayed in upper case character in the center of the page, shown as below:

EUCOL		17:13:57		< Meas Display >		TOOL			
FUNC A-B: Ls-Q FUNC C : OFF FUNC D : OFF FREQ : 5.50000kHz LEVEL : 1.5000V SPEED : MED RANGE : AUTO DC BIAS: 0.0000V				Ls: 2.48088mH Q : 0.78864				Vm: OFF Im: OFF	
Info: Use softkeys to select						Corr: OFF			
Meas Display	Bin Display	Pass Fail		List Sweep	Graph Sweep				



- 7) If the test result is obviously incorrect, please check the following items.
- a) Check the tested inductance is in good connection with the test fixture or not.
 - b) Check the test fixture is in good connection with the test terminals of the instrument or not.
 - c) Redo the open/short correction.

NOTE: When the sweep open/short correction is used, the point-frequency correction function should be set as OFF. Refer to Correction operation in this chapter.

5.5 Operation example of testing capacitance by multi-frequency list sweep

Test condition

Function: Cp-D

Level: 1Vrms

Other parameters

Frequency	Compare parameter	Low limit	High limit
1kHz	Cp(capacitance)	325.0nF	333.0nF
10kHz	D (Dissipation)	0.0008	0.0020
100kHz	D (Dissipation)	0.0060	0.0100



Beep: LONG

Alarm mode: OUT

Operation steps

- 1) Turn on the instrument.
- 2) Set basic parameters.
 - a) Press [MEAS DISP] to enter into the <MEAS DISPLAY> page.
 - b) The **FUNC A-B** zone is currently displayed as **Cp-D** and the Level zone is **1.000V**.
 - c) Press [MEAS SETUP] to enter into the <MEAS SETUP> page, meanwhile the following soft keys will be displayed in the soft key zone: **MEAS SETUP**, **CORRECTION**, **LIMIT TABLE**, **LIST SETUP** and **GRAPH SETUP**.
 - d) Press **LIST SETUP** to enter into the <LSIT SETUP> page.
 - e) Move the cursor to the **FUN** zone of sweep point 0, then the soft key zone will be displayed as **OFF, Ls, Lp, Cs, Cp, MORE**. Press **Cp** to set the parameter zone of sweep point 0.
 - f) Move the cursor to **FREQ** zone of sweep point 0, then this zone will displayed as **1.00000k**.
 - g) Move the cursor to **LEVEL** zone of sweep point 0, then this zone will displayed as **1.0000**.
 - h) Move the cursor to **LMT:LOW** zone of sweep point 0, then this zone will displayed as **0.00000pF**.
 - i) Press [3][2][5], +325 will be displayed in the prompt information zone and the following available units will be displayed in the soft key zone: **p, n, μ, m**. Press **n**, this zone will be changed as 325.000n.
 - j) Move the cursor to **LMT:HIGH** zone of sweep point 0, then this zone will displayed as **0.00000pF**.



- k) Press [3] [3] [3], +333 will be displayed in the prompt information zone and the following units will be displayed in the soft key zone: p, n, μ, m. Press n, this zone will be changed as 333.000n.
- l) Move the cursor to the **FUN** zone of sweep point 1, then the soft key zone will be displayed as OFF, Ls, Lp, Cs, Cp, MORE.
- m) Press MORE, then the soft key zone will display LESS, Rs, Rp, R, EST, MORE.
- n) Press MORE, then the soft key zone will display LESS, D, Q, MORE, Press D to set the parameter zone of sweep point 1.
- o) Move the cursor to **FREQ** zone of sweep point 1, then this zone will displayed as 1.00000k.
- p) Press [10], +10 will be displayed in the prompt information zone and the soft key zone will display the following available units: Hz, kHz and MHz. Press kHz, this zone will be displayed as 10.0000k.
- q) Move the cursor to **LEVEL** zone of sweep point 1, then this zone will displayed as 1.0000.
- r) Move the cursor to **LMT:LOW** zone of sweep point 1, then this zone will displayed as 0.00000p.
- s) Press [0][.][0][0][0][8], +0.0008 will be displayed in the prompt information zone and the soft key zone will display the following available units: p, n, μ, m. Press [ENTER], this zone will be changed as 800.000μ.
- t) Move the cursor to **LMT:HIGH** zone of sweep point 1, then this zone will displayed as 0.00000p.
- u) Press [0][.][0][0][2], +0.002 will be displayed in the prompt information zone and the soft key zone will display the following available units: p, n, μ, m. Press ENTER, this zone will be changed as 2.00000m.

Based on l-u steps, input 100kHz, 0.0060 and 0.0100 for the 3rd sweep point.

3) Alarm setup

- a) Press [SYSTEM] to enter into the <System Setup> page.
- b) Move the cursor to the **FAIL ALARM** zone to select **LONG**.



- 4) Mount the test fixture (U26005) to the test terminals of U2817A.
- 5) Execute correction function (To avoid the influence of the stray impedance on the measurement accuracy, it is necessary to execute open/short correction (refer to chapter 5.1.1 Sweep Correction)).
- 6) Insert the tested capacitor to the test fixture.
- 7) Execute test operations.

Press [MEAS DISP] and then List Sweep to enter into the <List Sweep Display> page. The instrument will test continuously and then display the test and the compare results on page. If the compare result is H (higher than the high limit) or L (lower than the low limit), there is a beep alarm. The following figure shows the measurement display page.

EUCOL		17:54:02		< List Sweep >		TOOL	
No.	FUN	CHH-CHL	FREQ[Hz]	LEV[V]	BIAS[x]	RESULT	COMP
0	CP	0 - 0	1.00000k	1.0000		325.633nF	PASS
1	D	0 - 0	10.0000k	1.0000		0.00098	PASS
*2	D	0 - 0	100.000k	1.0000		0.00814	PASS
3							
4							
5							
6							
7							
8							
9							
Info: Save completed				Corr: OPEN, SHORT			
Meas Display	Bin Display	Pass Fail		List Sweep	Graph Sweep		



- 8) If the test result is obviously incorrect, please check the following items.
 - d) Check the tested inductance is in good connection with the test fixture or not.
 - e) Check the test fixture is in good connection with the test terminals of the instrument or not.
 - f) Redo the open/short correction.

□ **NOTE:** When the sweep open/short correction is used, the point-frequency correction function should be set as OFF. Refer to Correction operation in this chapter.

5.6 Operation example of load correction

1) Operation steps

Test condition

Frequency: 100kHz

Cp: 11nF

D: 0.0005

- a) Press [MEAS SETUP], the following soft keys will be displayed in the soft key zone: **MEAS SETUP**, **CORRECTION**, **LIMIT TABLE**, **LIST SETUP**, **GRAPH SETUP**.
- b) Press **CORRECTION** to enter into the <CORRECTION> page.
- c) Move the cursor to Open, the following soft keys will be displayed in the soft key zone: **ON**, **OFF** and **SWEEP OPEN**.
- d) Press **ON** to turn on the open correction function.
- e) Move the cursor to Short, the following soft keys will be displayed in the soft key zone: **ON**, **OFF** and **SWEEP SHORT**.
- f) Press **ON** to turn on the short correction function.
- g) Move the cursor to **LOAD**, the following soft keys will be displayed in the soft key zone: **ON** and **OFF**.
- h) Press **ON** to turn on the load correction function.
- i) Move the cursor to **FUNC**, this zone will display **OFF**. Meanwhile **Cp—D**, **Cp—Q**, **Cp—G**, **Cp—Rp** and **MORE** will be displayed in the soft key zone.
- j) Press **Cp-D** to select the Cp-D function.



- k) Move the cursor to **SPOT FREQ** zone, the following soft keys will be displayed in the soft key zone: **ON**, **OFF**, **SPOT OPEN**, **SPOT SHORT** and **MEAS LOAD**.
- l) Press **ON** to turn on the point-frequency correction function of **SPOT FREQ**.
- m) Press [1][0][0], +100 will be displayed in the prompt information zone and the soft key zone will display the following available units: **Hz**, **kHz** and **MHz**. Press **kHz**, the **SPOT FREQ** zone will be changed as 100.000kHz (the same with the test frequency).
- n) Move the cursor to the **REF A:** zone of the frequency 1. Press [1][1], +11 will be displayed in the prompt information zone and the following available units will be displayed in the soft key zone: **p**, **n**, **μ**, **m** and **more 1/2**. Press **n**, this zone will be changed as 11.0000nF.
- o) Move the cursor the **REF B:** zone of the frequency 1. Press [0][.][0][0][0][5], +0.0005 will be displayed in the prompt information zone and the following available units will be displayed in the soft key zone: **p**, **n**, **μ**, **m**. Press **[ENTER]**, this zone will be changed as 0.00050.
- p) Move the cursor to **SPOT FREQ**. The following soft keys will be displayed: **ON**, **OFF**, **SPOT OPEN**, **SPOT SHORT** and **MEAS LOAD**.
- q) Hold the test fixture be in open status and keep user's hands or other interference source be far away from the test fixture. Press the soft key **SPOT OPEN** to execute open correction.
- r) Insert the short plate (U26010) into the test fixture. Please ensure that the short plate and the reeds of the test fixture have good contact.
- s) Press the soft key **SPOT SHORT** to execute short correction.
- t) Insert a standard capacitance into the test fixture. Please ensure that the pins of the standard capacitance have good connection with the reeds of the test fixture.
- u) Press the soft key **MEAS LOAD** to execute load correction.
- 2) Note**



- a) Because of the different software editions, the soft keys and status information may be different from this book, but it may not affect users' understanding.
- b) The load correction is only valid for the components with the same specification. If the specification is changed, it is required to redo load correction.



Chapter 6 Performance and Test

6.1 Test function

6.1.1 Parameter and symbol

C: capacitance	L: Inductance	
R: resistance	Z: impedance	Y: Admittance
X: reactance	B: susceptance	G: Conductance
D: dissipation	: phase angle	Q: Quality factor

DCR: DC resistance (OPTIONAL)

6.1.2 Test combination

Parameters described above are combined in the following modes:

Primary parameter	Z, Y	L, C	R	G
Secondary parameter	(deg phase), (rad radian)	D, Q, RS, RP, G	X	B

There is no combination for DCR.

6.1.3 Mathematical operation

Operation between the measurement value and the programmable nominal value:

absolute deviation Δ ABS and percent deviation Δ %.

6.1.4 Equivalent mode

Series and parallel

6.1.5 Range

Auto, Manual (Hold, increase and decrease)



6.1.6 Trigger

Internal, external and manual

Internal: Test DUT constantly and display the result

Manual: Press TRIGGER to test once then the result will be displayed.

External: After HANDLER receiving “start” signal, perform a measurement and output test result.

6.1.7 Delay time

Delay time: time from trigger to start. 0 to 60s are programmable with a resolution of 1ms.

6.1.8 Connection modes of test terminals

U2817A adopts 4-terminal test method.

HD(Hcur): current sample high terminal

LD(Lcur): Current sample low terminal

HS(Hpot): voltage sample high terminal

LS(Lpot): Voltage sample low terminal

6.1.9 Test speed (Frequency \geq 10kHz)

Fast: about 65 times/s (15ms/time)

Medium: about 25 times/s (40ms/time)

Slow: about 5 times/s (200ms/time)

The fast and middle speed will be slow down when frequency $<$ 10kHz.

6.1.10 Average

Be programmable from 1 to 255.



6.1.11 Display digit

6 digits, max. displayed digit: 999999

6.2 Test signal

6.2.1 Test signal frequency

Test signal is sine wave, accuracy: 0.01%

Frequency range: 50Hz~100kHz

Min. resolution: 0.1 mHz

6.2.2 Signal mode

Normal: When testing, on measurement display page, voltage across test terminals may be smaller than preset voltage.

Constant level: The auto adjustment of internal level makes the voltage of DUT accordant with preset voltage.

6.2.3 Test signal level

	Mode	Range	Accuracy	Resolution
	Normal	10mVRMS—2VRMS	$\pm (10\% \times \text{preset value} + 2\text{mV})$	
Voltage	constant	10mVRMS—1VRMS	$\pm (6\% \times \text{preset value} + 2\text{mV})$	10mV
	level			

When testing Turns Ratio, Phase, the voltage range is : 5mVRMS—10VRMS, $\pm (10\% \times \text{preset value} + 2\text{mV})$, with resolution of 1mV.



6.2.4 Output impedance

10 Ω , 30 Ω and 100 Ω are selectable.

6.2.5 Monitor for test signal level

Mode	Range	Accuracy
Voltage	10mVRMS—5VRMS	$\pm (3\% \times \text{reading} + 0.5\text{mV})$
Current	50 μ ARMS—20mARMS	$\pm (3\% \times \text{reading} + 5\mu\text{A})$

6.2.6 Maximum measurement display range

Parameter	Measurement display range
L、Lk	0.00001 μ H ~ 99.9999kH



C		0.00001pF ~ 9.99999F
Z、R、X、DCR		0.00001Ω~ 99.9999MΩ
Y、B、G		0.00001μs ~ 99.9999S
D		0.00001 — 9.99999
Q		0.00001 — 99999.9
θ	Deg	-179.999°~179.999°
	Rad	-3.14159 ~ 3.14159

6.3 Measurement accuracy

Test accuracy includes stability temperature coefficient linear degree test repeatability and calibration inter-error.

Check the accuracy of instrument should be under the following circumstances:

- a. warm-up time: ≥ 30 min
- b. cable: 0m, 1m
- c. correct open and short correction after warming up d. DC bias is in the position of “OFF”
- e. The range works in “AUTO” to select correct test range

6.3.1 Accuracies of $|Z|$, $|Y|$, L, C, R, X, G, B

The accuracy A_e of $|Z|$, $|Y|$, L, C, R, X, G and B are expressed as:



$A_e = \pm[A + (K_a + K_b + K_c) \times 100 + K_d + K_f] \times K_e$
 [%] A: basic test accuracy (figure A)

K_a: impedance rate factor (table A)

K_b: impedance rate factor (table A)

K_c: calibrated inter-factor (table B)

K_d: cable length factor (table D)

K_e: temperature factor (table E)

K_f: scan fixture modification factor (no add: K_f = 0, add: K_f = 0.2)

L, C, X, B accuracy using condition: D_x (Test value) ≤ 0.1

R, G accuracy using condition: Q_x (Q test value) ≤ 0.1

When $Q_x \geq 0.1$, R, G accuracy factor A_e should be multiplied by

Accuracy of G can only be available in G-B combination

6.3.2 Accuracy of D

The accuracy of D is given by D_e :

$$D_e = \frac{A_e}{100}$$

6.3.3 Accuracy of Q

The accuracy of Q is given by the formula below:

$$Q_e = x_e \times e_Q \times D_Q \times D_Q \times \pm 1\mu$$

Where, Q_x is the value of the tested Q.



De is the accuracy of D

Above formula should be used when $Q_x \times De < 1$.

6.3.4 Accuracy of θ

The accuracy of θ is given by the formula below:

$$\theta_e = \frac{180 \cdot Ae}{\pm 100} \quad [\text{deg}]$$

6.3.5 Accuracy of G

When D_x (tested value of D) ≤ 0.1

The accuracy of G is given by the formula below:

$$G_e = B_x \times D_e \quad [S]$$

$$B_x = 2\pi f C_x = \frac{1}{2fL_x}$$

Where, B_x is the value of tested B with the unit [S].

C_x is the value of tested C with the unit [F].

L_x is the value of tested L with the unit [H].

De is the accuracy of D.

F is test frequency.

The accuracy of G is only available in Cp-G and Lp-G combination



6.3.6 Accuracy of Rp

when D_x (value of tested D) ≤ 0.1

The accuracy of Rp is given by the formula below:

$$R_p = \frac{R_{px} \cdot D_e}{D_x \cdot D_e} \quad [\Omega]$$

Where, R_{px} is the value of tested Rp with the unit [S].

D_x is the value of test D with the unit [F].

D_e is the accuracy of D.

6.3.7 The accuracy of Rs

when D_x (value of tested D) ≤ 0.1

The accuracy of Rs is given by the formula below:

$$R_{se} = X_x \times D_e \quad [\Omega]$$

$$X_x = \frac{1}{2\pi f L_x} = \frac{1}{2\pi f C_x}$$

Where, X_x is the value of test X with the unit [S].

C_x is the value of test C with the unit [F].

L_x is the value of test L with the unit [H].

D_e is the accuracy of D

f is test frequency

—



6.3.8 Accuracy factor

Figure A shows the basic measurement accuracy A.

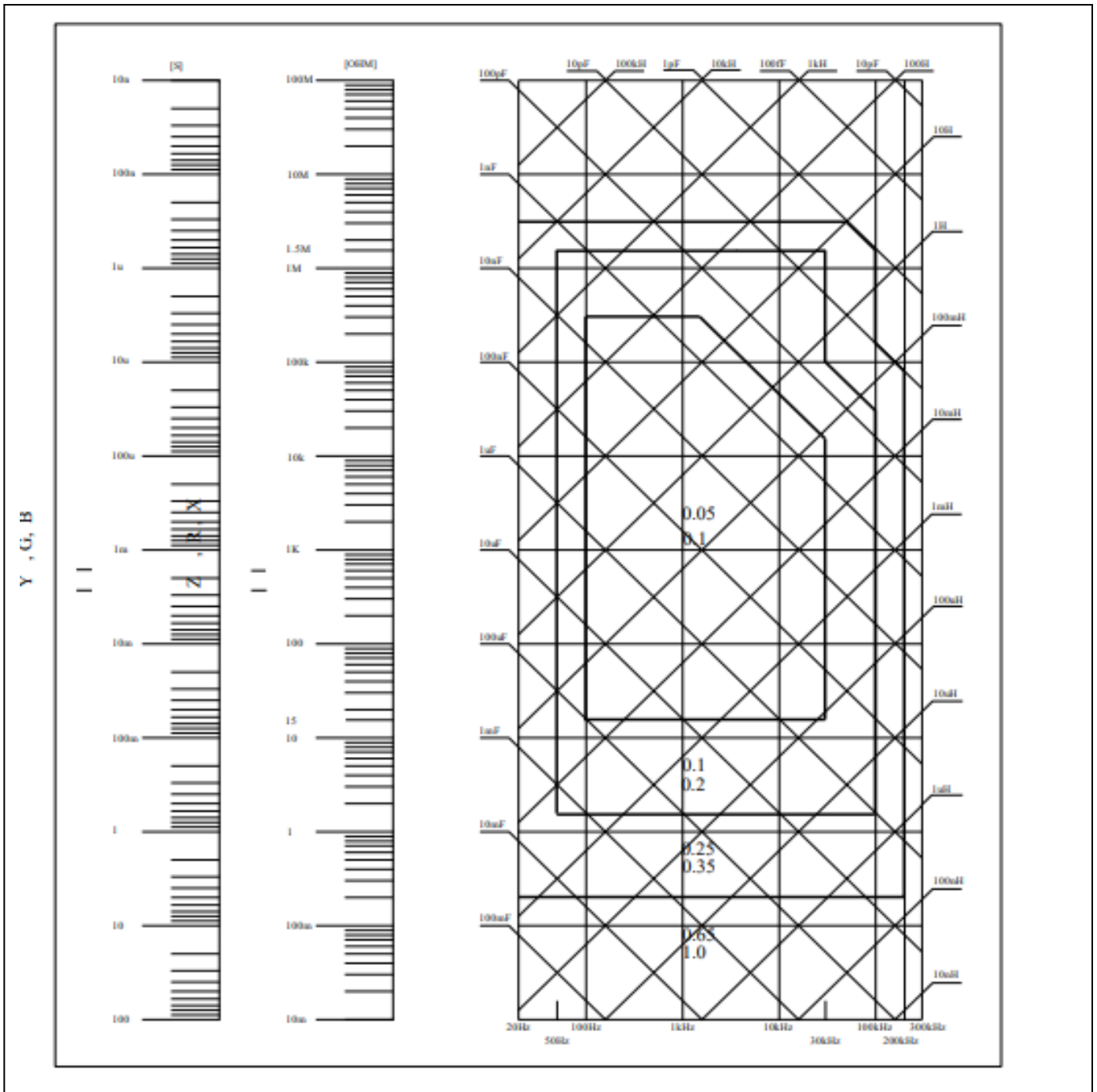



In figure A, select a smaller value on boundary line.

In this figure, the basic accuracy value A can be obtained by the following methods:

0.1---When $0.4V_{rms} \leq V_s \leq 1.2V_{rms}$, the test speed is the value A of medium, slow and fast.

0.2---When $0.4V_{rms} \leq V_s \leq 1.2V_{rms}$, the test speed is the value A.

When $V_s < 0.4V_{rms}$ or $V_s > 1.2V_{rms}$, the calculation method of value A is as the following steps:

1. Obtain A according to the current measurement speed;
2. According to the current test signal voltage to select the accuracy modification coefficient A_r (refer to figure B), the current basic measurement accuracy A is obtained by multiplying A got in step 1 with A_r .

Figure B is the basic accuracy modification curve, where V_s is the test signal voltage.

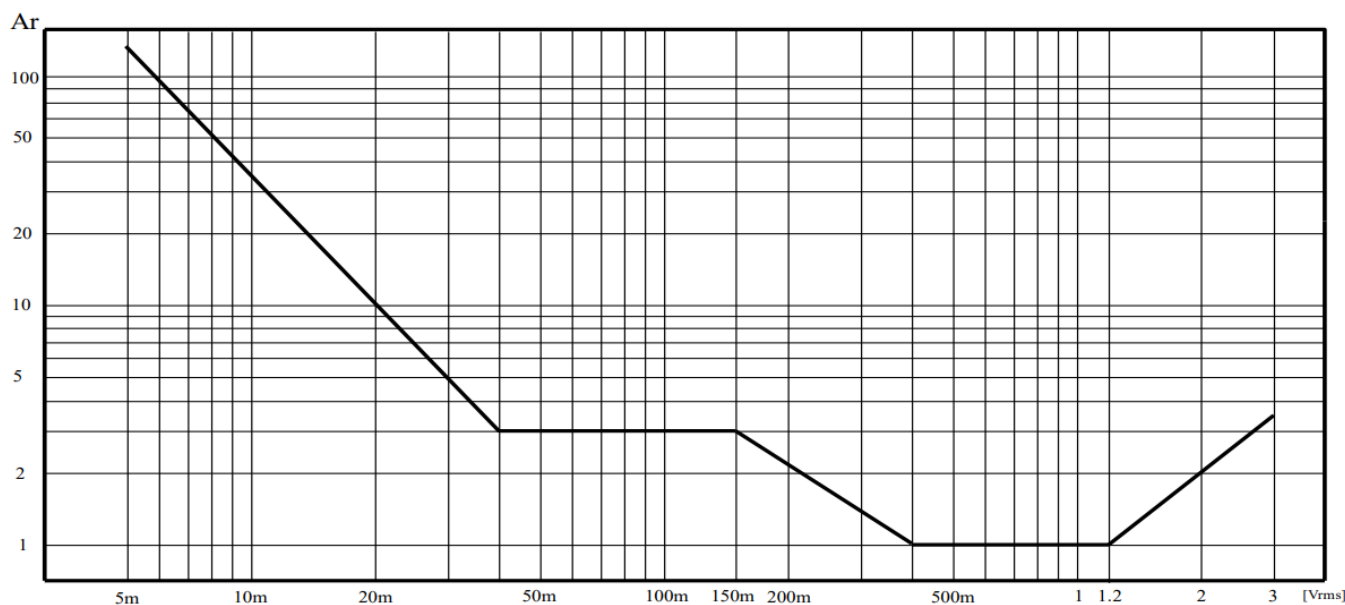



Table A Impedance rate factors: Ka, Kb

Speed	Frequency	K_a	K_b
Medium Slow	$f_m < 100\text{Hz}$	$(\frac{1 \times 10^{-3}}{ Z_m })(1 + \frac{200}{V_s})(1 + \sqrt{\frac{100}{f_m}})$	$ Z_m (1 \times 10^{-9})(1 + \frac{70}{V_s})(1 + \sqrt{\frac{100}{f_m}})$
	$100\text{Hz} \leq f_m \leq 100\text{kHz}$	$(\frac{1 \times 10^{-3}}{ Z_m })(1 + \frac{200}{V_s})$	$ Z_m (1 \times 10^{-9})(1 + \frac{70}{V_s})$
	$100\text{kHz} < f_m \leq 200\text{kHz}$	$(\frac{1 \times 10^{-3}}{ Z_m })(2 + \frac{200}{V_s})$	$ Z_m (3 \times 10^{-9})(1 + \frac{70}{V_s})$
Fast	$f_m < 100\text{Hz}$	$(\frac{2.5 \times 10^{-3}}{ Z_m })(1 + \frac{400}{V_s})(1 + \sqrt{\frac{100}{f_m}})$	$ Z_m (2 \times 10^{-9})(1 + \frac{100}{V_s})(1 + \sqrt{\frac{100}{f_m}})$
	$100\text{Hz} \leq f_m \leq 100\text{kHz}$	$(\frac{2.5 \times 10^{-3}}{ Z_m })(1 + \frac{400}{V_s})$	$ Z_m (2 \times 10^{-9})(1 + \frac{100}{V_s})$
	$100\text{kHz} < f_m \leq 200\text{kHz}$	$(\frac{2.5 \times 10^{-3}}{ Z_m })(2 + \frac{400}{V_s})$	$ Z_m (6 \times 10^{-9})(1 + \frac{100}{V_s})$

The unit of the tested impedance is [Ω].

The unit of the test signal voltage is [mVrms].

When the impedance is smaller than 500 Ω , Ka, Kb is unavailable.



When the impedance is larger than 500Ω, Ka, Kb is unavailable.

Table B calibrated interpolating factor Kc

Test frequency	Kc
Direct calibrated frequency	0
Other frequency	0.0003

Table C Direct Calibrated frequency

							50	60	80	[Hz]
100	120	150	200	250	300	400	500	600	800	[Hz]
1	1.2	1.5	2	2.5	3	4	5	6	8	[kHz]
10	12	15	20	25	30	40	50	60	80	[kHz]
100										[kHz]



There are 34 frequencies in table C.

Table D Cable length factor Kd

Test signal level	Cable length		
	0m	1m	2m
$\leq 1.5V_{rms}$	0	$2.5 \times 10^{-4} (1+50 \times fm)$	$5 \times 10^{-4} (1+50 \times fm)$
$> 1.5V_{rms}$	0	$2.5 \times 10^{-3} (1+16 \times fm)$	$5 \times 10^{-3} (1+50 \times fm)$

fm: test frequency [MHz]

Table E Temperature factor Ke

Temperature (°C)	5	8	18	28	38	
Ke	6	4	2	1	2	4

6.3.9 Accuracy of DCR

$$A(1+Rx/5M\Omega+16m\Omega/Rx)[\%] \pm 0.2m\Omega$$

When the instrument is in Middle and slow speed $A=0.25$

In Fast speed, $A=0.5$

Where, Rx is the tested resistance.

6.4 Safety requirement



The instrument is the I class safety instrument.

6.4.1 Insulation resistance

Under reference working condition, the insulation resistance between power terminal and instrument jacket should not be smaller than 50MΩ.

Under humidity condition, the insulation resistance between voltage terminal and instrument jacket should not be smaller than 2 MΩ.

6.4.2 Insulation intensity

Under reference working condition, the insulation between the power terminal and the instrument jacket should bear an AC voltage (50Hz frequency and 1.5kV rated voltage) for 1 minute and there is no breakdown and flashover.

6.4.3 Leakage current

The leakage current should not be larger than 3.5mA (AC effective value).

6.5 Electromagnetic compatibility

Transient sensitivity, based on the requirement of GB6833.4. Conductive sensibility, based on the requirement of GB6833.6. Radiated interference, based on the requirement of GB6833.10.

6.6 Performance test

6.6.1 Working condition

All tests should be performed under the working condition listed in Chapter 1. In this part, only the main indexes are listed. Users can make test under the specified condition mentioned in this manual. Performance test can be worked in the warm up conditions discussed in Chapter 1.

6.6.2 The used instruments and devices

No.	Instrument and Device	Specification
		100pF
		1000pF
1	Standard	10000pF
		0.02%



	capacitor		D is known
		10nF	
		0.1uF	

		1uF	
		10Ω	
		100Ω	
2	AC		
		1kΩ	0.02%
	standard resistor		
		10kΩ	
		100kΩ	
		0.1Ω	
		1Ω	
		10Ω	
	DC		0.02%

Based in New York City & Toronto, GAO Tek Inc. is ranked as one of the top 10 global B2B technology suppliers. GAO ships overnight within the U.S. & Canada & provides top-notch support thanks to its 4 decades of experience.



3		100Ω	
	standard resistor		
		1kΩ	
		10kΩ	
		100kΩ	
		100μH	
		1mH	
4	Standard inductor		0.02%
		10mH	
		100mH	
5	Frequency counter		(0~1000) MHz
6	Digital Multimeter		0.5%
7	Insulation resistance meter		500V 10 levels
			0.25kW
8	Hipot Tester		(0~500) V



--	--	--	--

6.6.3 Function check

Ensure function keys, displayer and terminal etc. can work normally.

6.6.4 Test signal level

Adjust multimeter in AC voltage range, where one test cable is connected to HCUR and the other is connected to ground terminal. Change level as: 10mV, 20mV, 100mV, 200mV, 1V, 2V, the reading should meet the demand of test signal level in this chapter.

6.6.5 Frequency

Connect frequency meter to ground terminal. The test terminal of the frequency meter is connected with HCUR. Change the frequency as: 20Hz, 100Hz, 1kHz, 10kHz, 100kHz. The reading of frequency meter should meet the demand of the test signal frequency in this chapter.

6.6.6 Measurement accuracy

Basic parameters are R, L, C and D, so measurement accuracy is mainly about R, L, C and D.

6.6.7 Accuracy of C and D

Function	Cp-D
Test frequency	100Hz 1kHz 10kHz 100kHz Test respectively
Level	1V
Range	AUTO
Bias	0V
Speed	Slow



Open and short correction should be made before testing. Connect standard capacitors: 100pF, 1000pF, 10nF, 0.1uF, 1uF and change the frequency. The error capacitance C between reading and nominal value should be in the range ruled in this chapter, dissipation D should be in the range ruled in this chapter.

6.6.8 Accuracy of L

Test condition:

Function	Ls-Q				
Test frequency	100Hz	1kHz	10kHz	100kHz	Test respectively
Level	1V				
Range	AUTO				
Bias	0V				
Speed	Slow				

Open and short correction should be made before testing. Connect standard inductors: 100μH, 1mH, 10mH, 100mH and change the frequency. The error between reading and nominal value should be in the range ruled in this chapter.

6.6.9 Accuracy of Z

Test condition:

Function	Z-θ				
Test frequency	100Hz	1kHz	10kHz	100kHz	Test respectively
Level	1V				



Range AUTO

Bias 0V

Speed Slow

Open and short correction should be made before testing. Connect standard AC resistors: 10 Ω , 100 Ω , 1k Ω , 10k Ω , 100k Ω and change the frequency. The error between reading and nominal value should be in the range ruled in this chapter.