

<b>Product Name</b>	<b>GAOTek Embedded Serial Port to Ethernet Module - WiFi and BT compatible</b>
<b>Product SKU</b>	<b>GAOTek-WM-133</b>
<b>Product URL</b>	<a href="https://gaotek.com/product/gaotek-serial-port-wireless-wifi-module/">https://gaotek.com/product/gaotek-serial-port-wireless-wifi-module/</a>



## Contents

1. OVERVIEW.....	4
2. FEATURES.....	4
3. SPECIFICATIONS .....	5
3.1 Product Specification .....	5
3.2 Hardware Specifications .....	7
3.2.1 System Block Diagram .....	7
3.2.2 Product Images.....	7
3.3.3 Pin Descriptions .....	8
3.4 Power Supply Characteristics .....	10
3.4.1 Supply Voltage .....	10
3.4.2 Power Supply Modes .....	10
4. INSTRUCTIONS.....	10
4.1 Power of Instruction.....	10
4.2 Indicator Instruction.....	10
4.3 Usage Instruction .....	10
4.4 Network Port Indicator Instruction .....	11
5. INTERFACE DESCRIPTION .....	11
6. PRODUCT FUNCTION.....	12
6.1 Default Parameters.....	12
6.2 Basic Functions .....	12
6.2.1 Set IP/ Subnet Mask/ Gateway .....	12
6.2.2 Restore Factory Settings .....	13
6.2.3 Firmware upgrades.....	13
6.2.4 AT Command Function Settings .....	13
6.2.5 Data Transmission Function .....	14
6.3 Socket Function .....	14
6.3.1 TCP Client.....	14
6.3.2 TCP Server.....	14
6.3.3 UDP Client.....	15
6.3.4 UDP Server .....	15
6.4 Serial Port Function .....	15



---

6.4.1 AT Command Settings .....	15
6.4.2 Transmitting Serial Data .....	15
6.5 Bluetooth Function.....	15
6.5.1 Bluetooth Data Transmission.....	15
6.6 Wi-Fi Function.....	16
6.6.1 Internet Access .....	16
6.7 Cable Network Access Function.....	16
6.7.1 Internet Access.....	16

## 1. OVERVIEW

GAOTek Embedded Serial Port to Ethernet Module - WiFi and BT compatible is an embedded serial port to Ethernet module based on series launched. Integrating an optimized TCP/IP protocol stack, it makes it easy for users to accomplish the network access of embedded devices and greatly reduces the development time cost. Moreover, the module is designed to be compatible with half pads and through-hole connectors. As the board width of it is the generic width, the module can be directly welded to boards, or connectors, or even breadboards, which is convenient for users to apply in different scenes. The series IC is the SOC integrated with 2.4 GHz Wi-Fi and BT dual modes with ultra-high RF performance, stability, versatility, reliability, and ultra-low power consumption.

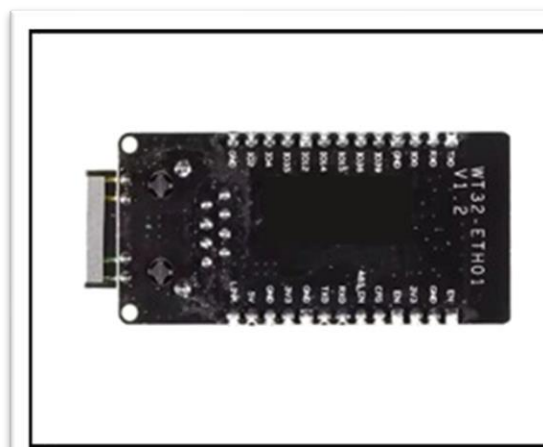
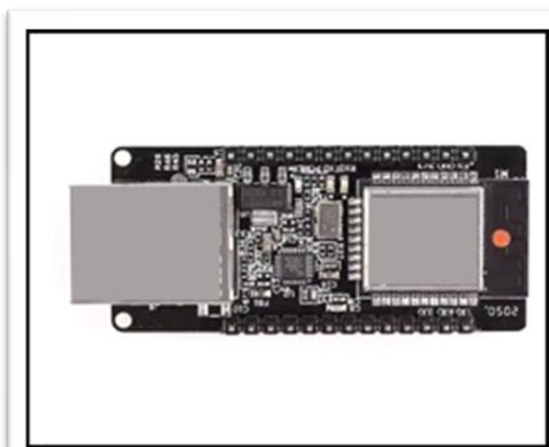

## 2. FEATURES

- **Serial-to-Ethernet Conversion:** The module allows devices with serial interfaces to communicate over Ethernet.
- **Efficient Communication:** The optimized TCP/IP stack ensures reliable data transmission.
- Support user secondary development and wired network access.



### 3. SPECIFICATIONS

#### 3.1 Product Specification

Category	Items	Product specifications
Wi-Fi	RF certifications	FCC/CE/RoHS
	Protocols	802.11 b/g/n/e/i (802.11n, Up to 150 Mbps)
		A-MPDU and A-MSDU aggregation, 0.4_s guard interval support
	Frequency range	2.4-2.5 GHz
Bluetooth	Protocols	Bluetooth v4.2 BR/EDR and BLE standards
	Radio	NZIF receiver with -97 dBm sensitivity
Hardware	Network port specification	RJ45, 10/100Mbps, Cross-direct connection adaptive
	Serial baud rate	80-5000000
	On-board flash	32Mbit
	Operating voltage	5V or 3.3V
	Operating Current	Average: 80mA
	Supply current	Minimum: 500 mA



	<b>Operating System</b>	-40°C--+85°C
	<b>Ambient Temperature</b>	Normal temperature
	<b>Packaging</b>	Half pad/ Through-hole connector (Optional)
<b>Software</b>	<b>Wi-Fi mode</b>	Station/softAP/SoftAP+station/P2P
	<b>Wi-Fi security Mechanism</b>	WPA/WPA2/WPA2-Enterprise/WPS
	<b>Encryption types</b>	AES/RSA/ECC/SHA
	<b>Firmware update</b>	Remote OTA upgrade via network
	<b>Software Development</b>	SDK used for further development
	<b>Networking protocol</b>	IPv4, TCP/UDP
	<b>IP access method</b>	Static IP, DHCP (default)
	<b>Transparent transmission modes</b>	TCP Server/TCP Client/UDP Server/UDP Client
	<b>User configurations</b>	AT+ commands set

## 3.2 Hardware Specifications

### 3.2.1 System Block Diagram

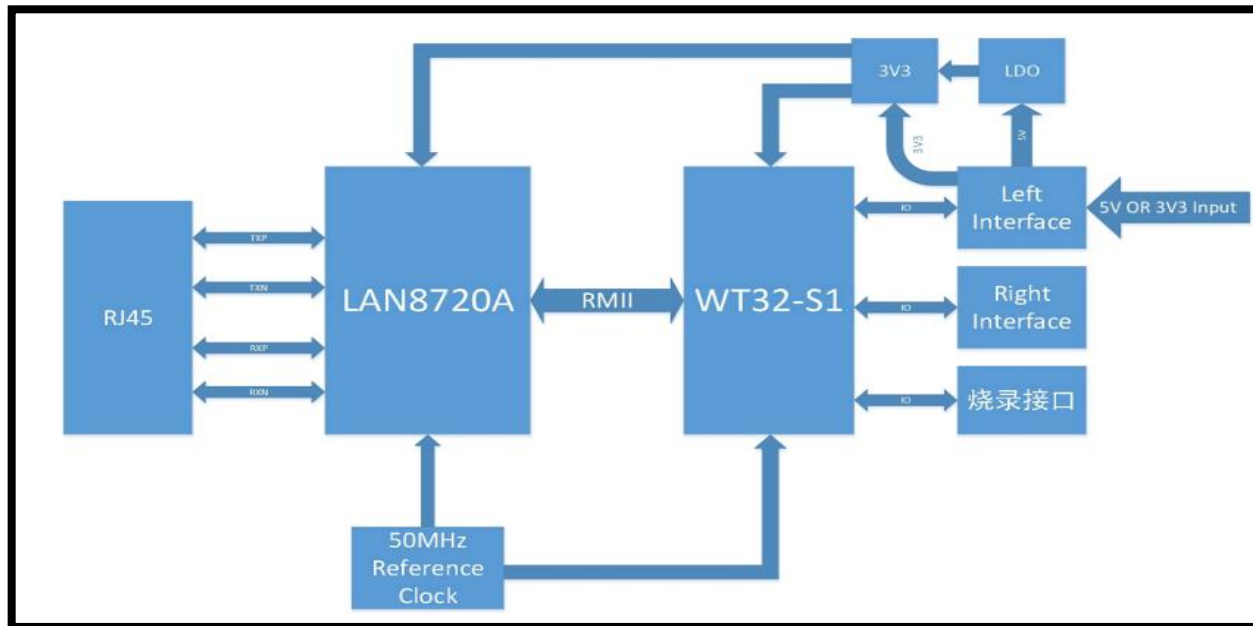

### 3.2.2 Product Images

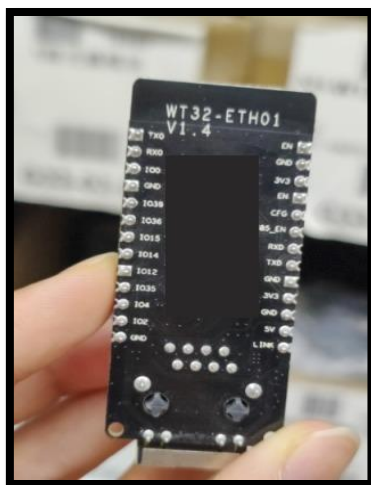

### 3.3.3 Pin Descriptions

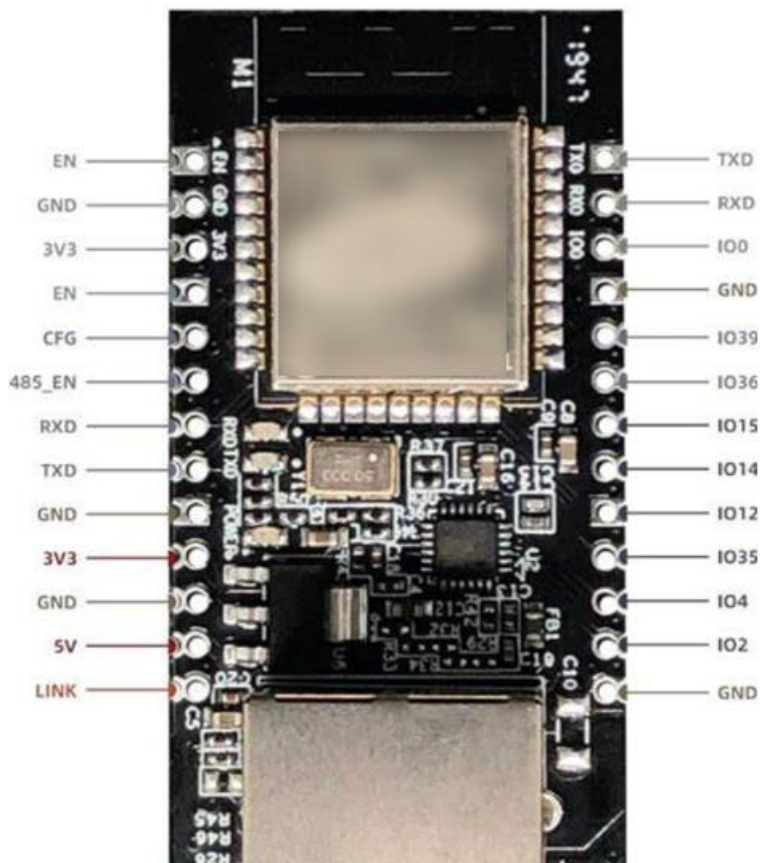

#### DEBUGGING/ BURNING INTERFACE

Pin	Name	Description
1	EN <sup>1</sup>	Reserved debugging/burning interface; Active-high enable
2	GND	Reserved debugging/burning interface; GND
3	3V3	Reserved debugging/burning interface; 3V3
4	TXD	Reserved debugging/burning interface; 101, TXDO
5	RXD	Reserved debugging/burning interface; 103, RXDO
6	100	Reserved debugging/burning interface; 100



DESCRIPTION		
Pin	Name	Description
1	EN <sup>1</sup>	Active-high enable
2	CFG	1032, CFG
3	485_EN	1033, RS485 Enable pin
4	RXD	105, RXD2
5	TXD	1017, TXD2
6	GND	GND
7	3V3 <sup>2</sup>	3V3 Power supply
8	GND	GND
9	5V <sup>2</sup>	5V Power supply
10	LINK	Network connection indicator pin
11	GND	GND
12	1039 <sup>3</sup>	1039, Input only
13	1036 <sup>3</sup>	1036, Input only
14	1015	1015
15	1014	1014
16	1012	1012
17	1035	1035, Input only
18	104	104
19	102	102
20	GND	GND

**Note 1:** The module enables high level by default.

**Note 2:** Power supply makes a binary choice between 3V3 and 5V.

**Note 3:** 1039, 1035 and 1036 only support input.

## 3.4 Power Supply Characteristics

### 3.4.1 Supply Voltage

You can make a binary choice between 3V3 and 5V for power supply voltage of the module.

### 3.4.2 Power Supply Modes

Users can choose from the following modes flexibly according to their needs:

1. Through hole (Welding pins):
  - Power supply with Dupont line connection.
  - Power supply with breadboard connection
2. Half pad (Directly welded to the board): Power supply of user board.

## 4. INSTRUCTIONS

### 4.1 Power of Instruction

If the Dupont line connection is used: Find the 3V3 or 5V power input port and connect the corresponding voltage to it; when LED1 indicator lights up, it indicates that power is on.

### 4.2 Indicator Instruction

- LED1: Power light, when the power supply is normal, the indicator light is on.
- LED3: Serial port indicator, RXD2(I05) When there is data flow, the indicator light is on.
- LED4: Serial port indicator, TXD2(I017) When there is data flow, the indicator light is on.

### 4.3 Usage Instruction

Users can choose from three ways of use according to their needs:

1. Through hole (Welding pins): Dupont line connection.
2. Through hole (Welding pins): breadboard connection.
3. Half pad: Users can directly weld the module on their own board.

#### 4.4 Network Port Indicator Instruction

Network Port Indicator	Function	Description
<b>Green Indicator</b>	Connection status indication	When properly connected to the network, the green light is on.
<b>Yellow Indicator</b>	Data indication	The indicator flashes when the module receives or sends data, including receiving network broadcast package.

### 5. INTERFACE DESCRIPTION

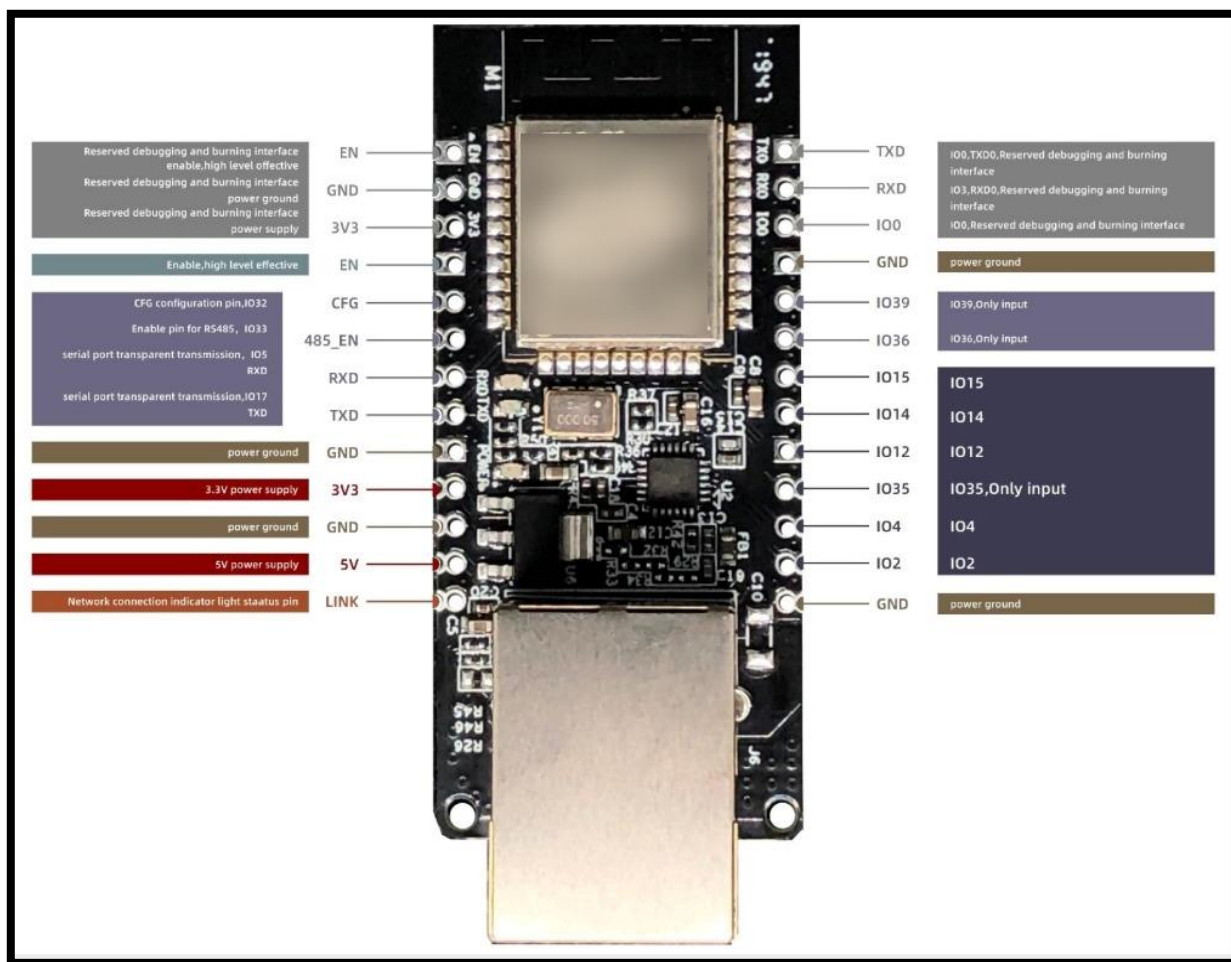

## 6. PRODUCT FUNCTION

### 6.1 Default Parameters

Items	Descriptions
Port Baud Rate	115200
Serial port parameters	None/8/1
Transparent Transmission Channel	Serial to Ethernet transparent transmission channel

### 6.2 Basic Functions

#### 6.2.1 Set IP/ Subnet Mask/ Gateway

1. IP address is the identity representation of the module in the LAN, which is unique in the LAN, so it cannot be repeated with other devices in the same LAN. There are two ways to obtain the IP address of the module: static IP and DHCP / dynamic IP.

##### a) Static IP

Static IP needs to be set manually by the user. In the process of setting, attention should be paid to write IP, subnet mask and gateway at the same time. Static IP is suitable for scenarios where IP and devices need to be counted and correspond to each other. You should pay attention to the correspondence of IP address, subnet mask and gateway when setting. To use static IP, you need to set each module and ensure that the IP address is not repeated with other network devices in the LAN.

##### b) DHCP/Dynamic IP

The main function of DHCP / Dynamic IP is to dynamically obtain IP address, gateway address, DNS server address and other information from the gateway host to avoid the tedious steps of setting IP address. It is applicable to scenarios where there is no requirement for IP, and it is not required to have a one-to-one correspondence between IP and module.

2. The subnet mask is mainly used to determine the network number and host number of the IP address, indicate the number of subnets, and determine whether the module is in the subnet. The subnet mask must be set properly. The commonly used class C subnet mask is 255.255.255.0. The network number is the first 24 bits, the host number is the last 8 bits, and the number of subnets is 255. If the module IP is within the range of 255, it is considered that the module IP is in the subnet.
3. Gateway refers to the network number of the current IP address of the module. If the module connects to the external network by accessing devices such as routers, the gateway is the IP address of the router. If the setting is wrong, the external network cannot be connected correctly. If you do not connect to devices such as routers, you do not need to set it. It's OK by default.

### 6.2.2 Restore Factory Settings

1. Restore factory settings by AT command: restore factory settings via AT+ RESTORE.
2. Restore factory settings by hardware: CFG to ground, restart the module.

### 6.2.3 Firmware upgrades

OTA remote upgrade is the way for modules to upgrade firmware, through which more application functions can be obtained.

- a) Firmware upgrade can be connected to the network through wired network or Wi-Fi.
- b) Operate GPIO2 to ground, restart the module, and enter OTA upgrade mode.
- c) After the upgrade is completed, disconnect GPIO2 from the ground, restart the module, and it enters the normal working mode.

OTA firmware upgrade instructions: when the firmware is being downloaded, the serial port TXD indicator flashes quickly; when the download is being upgraded, the serial port TXD indicator is always on; when the upgrade is successful, the serial port TXD and RXD indicators are always on; when the upgrade fails, the serial port TXD indicator flashes slowly.

### 6.2.4 AT Command Function Settings

- Users can set functions of the module by inputting AT commands through serial ports.
- Refer to the ESP32 AT instruction set for details.

## 6.2.5 Data Transmission Function

- The module has four data transmission ports: Serial port, Wifi, Ethernet and Bluetooth.
- Users can use AT commands to combine the four data ports in pairs for data transmission.
- Use AT+PASSCHANNEL command to set/query the module's transparent transmission channel. After the setting is complete, the module needs to be restarted to take effect.

## 6.3 Socket Function

- The Socket working mode of the module is divided into four types: TCP Client, TCP Server, UDP Client, and UDP Server, which can be set by AT command.
- For AT command operation, please refer to esp32 wired module AT command routine v1.2.

### 6.3.1 TCP Client

1. TCP Client provides client connection for TCP network services. It initiates connection request and establish connection to the server to realize the interaction between serial port data and server data. According to the relevant provisions of TCP protocol, TCP client has the difference between connection and disconnection to ensure the reliable exchange of data. Usually used for data interaction between devices and servers, it is the most common way of networking communication.
2. When the module connects TCP server as a TCP client, it needs to pay attention to the parameters such as the target IP / domain name and the target port number. Target IP can be of a local device in the same LAN. It can also be an IP address from a different LAN or an IP address across the public network. If connecting to a server across the public network, the server is required to have a public IP.

### 6.3.2 TCP Server

It is usually used for communication with TCP client in LAN. It is suitable for the scenario where there is no server in the LAN and there are multiple computers or mobile phones requesting data from the server. The same as TCP Client, TCP server has the difference between connection and disconnection to ensure reliable exchange of data.

### 6.3.3 UDP Client

- UDP Client is a connectionless transport protocol, providing transaction-oriented simple and unreliable information transmission services.
- There is no connection establishment or disconnection, and data can be sent to each other only by specifying IP and port.
- It is usually used in data transmission scenarios where there is no requirement for the packet loss rate, the data packets are small and the transmission frequency is relatively fast, and the data is transferred to the specified IP.

### 6.3.4 UDP Server

- UDP Server means that the source IP address is not verified on the basis of ordinary UDP. After receiving a UDP packet, the destination IP is changed to the data source IP and port number. When sending data, send it to the IP and port number of the most recent communication.
- This mode is usually used in data transmission scenarios where multiple network devices need to communicate with the module and do not want to use TCP due to the high speed and frequency.

## 6.4 Serial Port Function

### 6.4.1 AT Command Settings

Users can input AT commands through serial ports to set functions for a module.

### 6.4.2 Transmitting Serial Data

The user makes the module enter the data transmission mode through AT command. The module can directly transfer serial port data to the corresponding data transmission end (wifi, Ethernet or Bluetooth) through the set passthrough channel.

## 6.5 Bluetooth Function

### 6.5.1 Bluetooth Data Transmission

Through the existing Bluetooth function of the module, the module can obtain Bluetooth data, and through the set pass-through channel, the Bluetooth data can be directly transferred to the corresponding data transmission end (Wi-Fi, Ethernet, or serial port).

## 6.6 Wi-Fi Function

### 6.6.1 Internet Access

The module wifi is connected to the Internet or LAN through a router. The user configures the socket function through the AT command. The module can establish a TCP/UDP connection and then access the user's designated server.

## 6.7 Cable Network Access Function

Stable network connection can be obtained through wired network to ensure stable network data acquisition.

### 6.7.1 Internet Access

The module is connected to the Internet or LAN through a wired network. The user configures the socket function through the AT command. The module can establish a TCP/UDP connection and then access the user's designated server.



**Contact us: [sales@gaotek.com](mailto:sales@gaotek.com)**