



Product Name	GAOTek Earth Resistance XDSL Tester
Product SKU	GAOTek-XDSL-156
Product URL	https://gaotek.com/product/gaotek-earth-resistance-xdsl-tester/

Based in New York City & Toronto, GAO Tek Inc. is ranked as one of the top 10 global B2B technology suppliers. GAO ships overnight within the U.S. & Canada & provides top-notch support thanks to its 4 decades of experience.



Contents

GAOTek Earth Resistance XDSL Tester	3
Safety rules and precautions	4
Introduction.....	5
Range and accuracy	6
Model of Series	7
Technical Specification.....	8
Structure.....	10
Interface display	11
1 Interface.....	11
2 Interface icon symbol description.....	12
Measuring Principle	13
1 Principle of Clamp Method Resistance Measurement.....	13
2 Three-four-wire method measurement principle	13
3 Selection method measurement principle	14
4 Principle of Soil Resistivity Measurement.....	15
5 Working error principle	15
6 AC current measurement principle	16
7 Ground voltage measurement principle	16
Operation Method	16
1 Switch machine.....	16
2 Function selection	16
3 Clamp measurement	16
4 Three-four-wire method measurement.....	17
5 Ground voltage measurement	18
6 AC current measurement	18
7 Selection method	19
8 Soil resistivity measurement.....	20
8 Data query and deletion	21
9 Alarm Settings	21
Mobile APP Instructions	22
Field Application.....	23
1 Multi-point grounding system	23
2. Limited point grounding system	24
3.Single point grounding system	25
4. Two-point method	25
5. Three-point method	26
Packing List	27

Based in New York City & Toronto, GAO Tek Inc. is ranked as one of the top 10 global B2B technology suppliers. GAO ships overnight within the U.S. & Canada & provides top-notch support thanks to its 4 decades of experience.



GAOTek Earth Resistance XDSL Tester

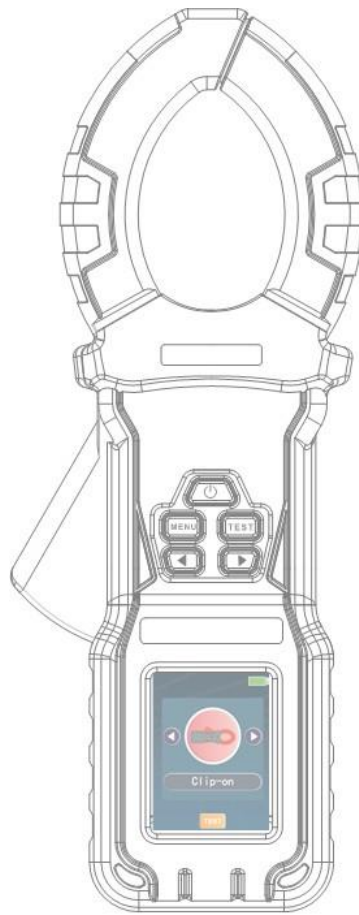

Based in New York City & Toronto, GAO Tek Inc. is ranked as one of the top 10 global B2B technology suppliers. GAO ships overnight within the U.S. & Canada & provides top-notch support thanks to its 4 decades of experience.



Safety rules and precautions

Thank you for purchasing our company's Earth Resistance XDSL Tester. In order to better use this product, please be sure to:

- Read this user manual in detail.
- Strictly follow the safety rules and precautions listed in this manual.

This instrument according to IEC61010 safety specifications for design, production, inspection.

In any case, use the meter should pay special attention to safety.

When measuring, please do not use the high frequency signal generator such as mobile phone near the instrument, so as not to cause error.

Pay attention to the label and symbol of the instrument.

Make sure the instrument and accessories are in good condition before use.

Before starting up, press the trigger once or twice to make sure the jaws are well closed.

Do not measure in flammable places, sparks may cause an explosion.

When starting up, do not press the trigger or clamp any wires.

Power on, the "OL" symbol is displayed during the clamp method measurement, then measured object can be clamped.

Do not place or store the meter for a long time in a place with high temperature, humidity, condensation, or under direct sunlight.

Must turned off the meter When replacing the battery.

When the low battery low voltage symbol "" display, the battery should be replaced in time, otherwise it will cause errors.

The contact surface of the jaws must be kept clean and cannot be wiped with corrosive agents and rough objects.

When opening the trigger, avoid impact on the clamp meter, especially the jaw joint surface.

Based in New York City & Toronto, GAO Tek Inc. is ranked as one of the top 10 global B2B technology suppliers. GAO ships overnight within the U.S. & Canada & provides top-notch support thanks to its 4 decades of experience.



The clamp will make a slight noise when measuring resistance. This is normal. Note the "beep-beep-beep-" sound to distinguish the alarm.

Pay attention to the measurement range and use environment specified of this instrument.

The measurement lead current should not exceed the upper limit of the clamp meter.

Use, disassembly, calibration and maintenance of this instrument must be operated by authorized personnel.

Due to the reasons of this instrument, if it is dangerous to continue using it, it should be stopped immediately, sealed up immediately, and handled by an authorized organization.

The "  safety warning signs in the instrument and manual must be strictly followed by the user. Allow safe operation.

Introduction

GAOTek Earth Resistance XDSL Tester also name Loop resistance tester, used for grounding resistance test.

This instrument uses 2.4-inch color screen design, with clamp resistance, three or four wire resistance, AC voltage, current measurement functions, and also has data storage, data access, alarm, automatic shutdown and other functions.

This meter is beautiful and high-grade, wide range, high resolution, convenient operation, easy to carry, accurate, reliable, stable performance, strong anti-interference ability. It also has a shock-proof, dust-proof, and moisture-proof structure. It is a commonly used and indispensable instrument for telecommunications, electric power, meteorology, computer rooms, oil fields, electronic mechanical installation and maintenance, and industrial enterprises that use electricity as industrial power or energy. It is suitable for measuring grounding resistance of various telecommunications, electricity, meteorology, computer rooms, oil fields, power distribution lines, transmission lines of iron towers, gas stations, factory grounding grids, lightning rods, etc.

The ground-pile clamp ground resistance tester is controlled by a microprocessor and can accurately detect ground resistance. It uses fast filtering technology to minimize interference. At the same time with data storage and data upload functions.

Based in New York City & Toronto, GAO Tek Inc. is ranked as one of the top 10 global B2B technology suppliers. GAO ships overnight within the U.S. & Canada & provides top-notch support thanks to its 4 decades of experience.



Range and accuracy

Measurement mode	Range	Resolution	Accuracy
Clamp method	0.02Ω-9.99Ω	0.01Ω	±2%rdg±0.1Ω
	10.0Ω-99.9Ω	0.5Ω	±3%rdg±0.5Ω
	100Ω-199Ω	1Ω	±5%rdg±1Ω
	200Ω-299Ω	5Ω	±10%rdg±5Ω
	300-699Ω	10Ω	±15%rdg±10Ω
	700Ω-999Ω	20Ω	±20%rdg±20Ω
	1.00KΩ-1.19KΩ	30Ω	±25%rdg±30Ω
	1.20KΩ-2.00KΩ	50Ω	±35%rdg±50Ω
three or four wire method	0.01Ω-9.99Ω	0.01Ω	±2%rdg±0.2Ω
	10.0Ω-99.9Ω	0.1Ω	±2%rdg±1Ω
	100Ω-999Ω	1Ω	±2% rdg±15Ω
	1.00KΩ-9.99KΩ	0.01KΩ	±2% rdg±0.1KΩ
	10.0KΩ-30.0KΩ	0.1KΩ	±3% rdg±0.5KΩ
AC current	0.100mA -0.999mA	0.001mA	±2.5% rdg±0.1mA
	1.00mA -9.99mA	0.01mA	±2.5% rdg±0.5mA
	10.0mA -99.9mA	0.1mA	±2.5% rdg±1mA
	0.100A-0.999A	0.001A	±2.5% rdg±0.1A
	1.00A-9.99A	0.01A	±2.5% rdg±0.5A
	10.0A-60.0A	0.1A	±2.5% rdg±1A
Ground voltage	1.00V-9.99V	0.01V	±2.5% rdg±0.1V
	10.0V-99.9V	0.1V	±2.5% rdg±1V
	100V-600V	1V	±2.5% rdg±5V
Selection method	0.30Ω-9.99Ω	0.01Ω	±2% rdg±0.3Ω
	10.0Ω-99.9Ω	0.1Ω	±2% rdg±1Ω
	100Ω-999Ω	1Ω	±2.5% rdg±15Ω
	1.00KΩ-3.00KΩ	0.01KΩ	±3% rdg±0.1KΩ
	0.00Ωm~99.99Ωm	0.01Ωm	

Based in New York City & Toronto, GAO Tek Inc. is ranked as one of the top 10 global B2B technology suppliers. GAO ships overnight within the U.S. & Canada & provides top-notch support thanks to its 4 decades of experience.



Soil resistivity (ρ)	100.0 Ω m~999.9 Ω m	0.1 Ω m	$\rho=2\pi aR$ (note1)
	1000 Ω m~9999 Ω m	1 Ω m	
	10.00k Ω m~99.99k Ω m	10 Ω m	
	100.0k Ω m~999.9k Ω m	100 Ω m	
	1000k Ω m~9999k Ω m	1k Ω m	

Note 1: R depends on the measurement accuracy of the three-four-wire method, $\pi=3.14$, a: 1 m~100m;

Model of Series

Model	ES3022	ES3022E	ES3022F
Clamp resistance Range	0.00 Ω -1500 Ω	0.00 Ω -1800 Ω	0.00 Ω -2000 Ω
Leakage current range	0.000mA-40A	0.000mA-50A	0.000mA-60A
Current resolution	1 μ A	1 μ A	1 μ A
Three-four-wire method range	0.00 Ω -3000 Ω	0.00 Ω -30k Ω	0.00 Ω -30k Ω
Soil resistivity range	○	0.00 Ω -9999k Ω m	0.00 Ω -9999k Ω m
Ground voltage range	600V	600V	600V
Bluetooth	○	○	●
Built-in rechargeable battery	●	●	●
TFT Color display	●	●	●
USB Data upload function	●	●	●
data storage	●	●	●
Real-time battery power indicator	●	●	●

Based in New York City & Toronto, GAO Tek Inc. is ranked as one of the top 10 global B2B technology suppliers. GAO ships overnight within the U.S. & Canada & provides top-notch support thanks to its 4 decades of experience.



Backlight	•	•	•
Alarm function	•	•	•
Low battery voltage indication	•	•	•
Overload protection	•	•	•
<input type="radio"/> No <input checked="" type="radio"/> Yes			

Technical Specification

Function	Ground resistance test, loop resistance test, AC current test, AC voltage test
Accuracy guaranteed temperature and humidity	23°C±5°C, below 75%rh
Power Supply	DC 3.7 Lithium battery
Resistance resolution	0.01Ω
Current resolution	0.001mA
Voltage resolution	0.01V
Clamp Size	68mm
Display	2.4 inch color LCD screen

Based in New York City & Toronto, GAO Tek Inc. is ranked as one of the top 10 global B2B technology suppliers. GAO ships overnight within the U.S. & Canada & provides top-notch support thanks to its 4 decades of experience.



LCD Size	46mm×29mm
Meter Dimension	273mm×106mm×53mm
measure time	1 time/sec
USB	With USB interface,uploaded the data to the computer, saved and printed
Communication line	USB communication line 1
Data storage	Maximum 500 groups of data, display "FULL" symbol to indicate that the storage is full
Overflow display	“OL” symbol indication when over-range overflow
Alarm function	When the measured value exceeds the alarm set value, an alarm will be issued
battery voltage	Real-time display of battery power, reminding to charge in time when battery voltage is low
Automatic shut-down	Turn off automatically after 15 minutes
Power consumption	750mA MAX
Quality	Meter: 975g (including battery)
Working temperature and humidity	-10°C~50°C; Below 80%rh
Storage Temperature and Humidity	-10°C~60°C; below 70%rh
Insulation Resistance	20Ω or more (500V between circuit and outside)
Pressure Resistance	AC 3700V/rms(between circuit and outside)
External magnetic field	<40A/m
External electric field	<1V/m
Suitable for Safety Regulations	IEC61010-1(CAT III 300V、CAT IV 600V、Pollution Degree 2); IEC61010-031;IEC61557-1(Ground resistance)

Based in New York City & Toronto, GAO Tek Inc. is ranked as one of the top 10 global B2B technology suppliers. GAO ships overnight within the U.S. & Canada & provides top-notch support thanks to its 4 decades of experience.



Structure

- 1. Clamp
- 2. Jaw opening and closing trigger
- 3. MENU key
- 4. ▲
- 5. Power button
- 6. TEST
- 7. ▼
- 8. Screen
- 9. E port
- 10. H port
- 11. USB interface
- 12. Charging indicator
- 13. ES port
- 14. S port

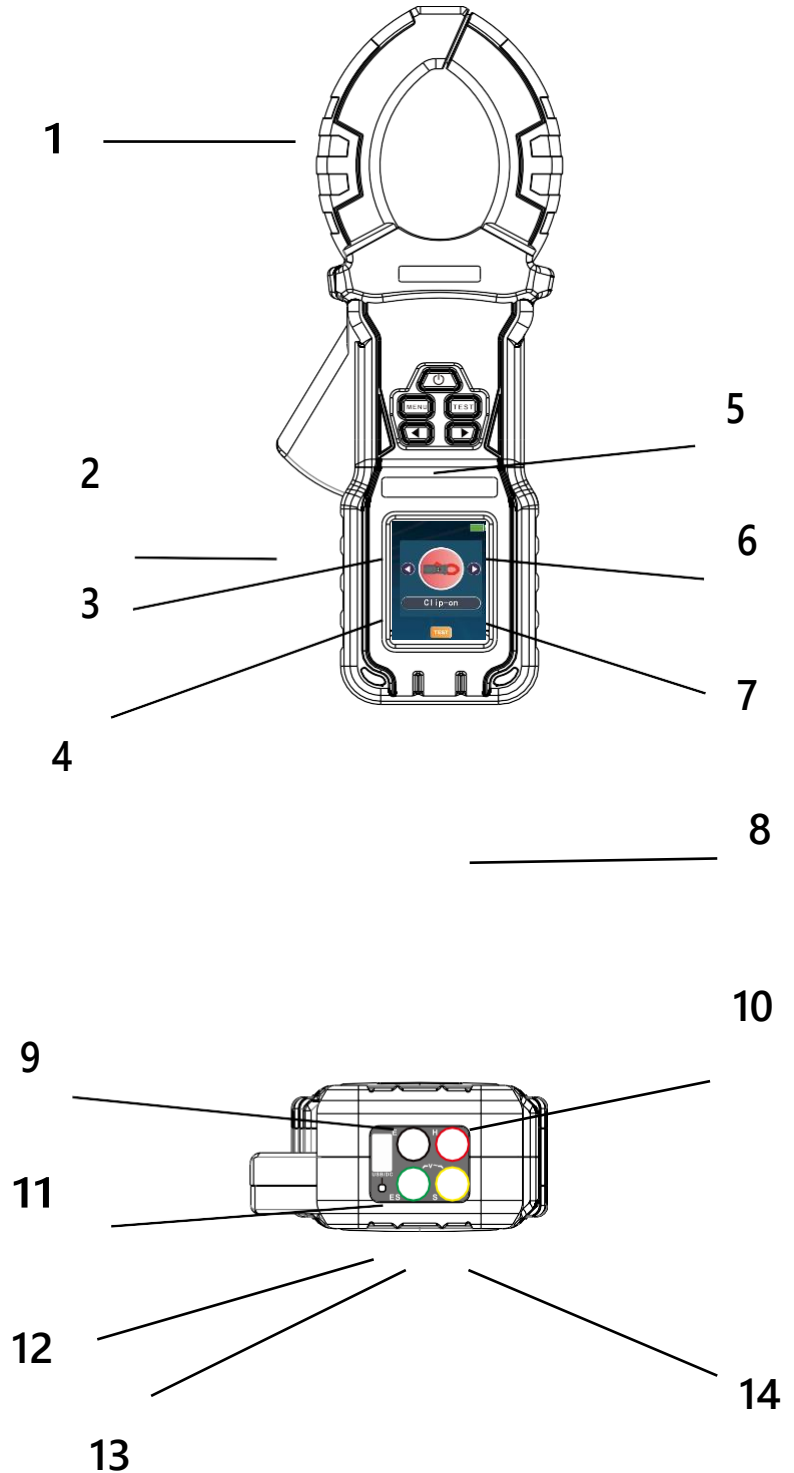

Based in New York City & Toronto, GAO Tek Inc. is ranked as one of the top 10 global B2B technology suppliers. GAO ships overnight within the U.S. & Canada & provides top-notch support thanks to its 4 decades of experience.

Interface display

1 Interface



(1) Main interface

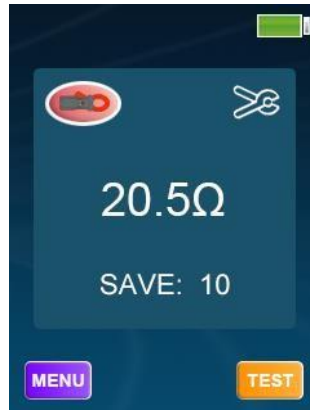

(2) Pincer

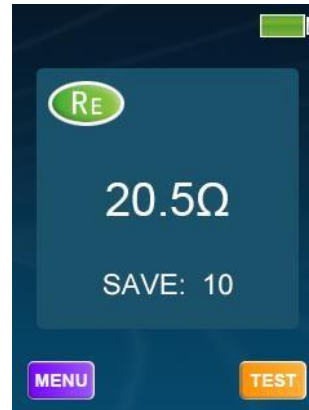

(3) Three/four line



(4) Voltage measurement

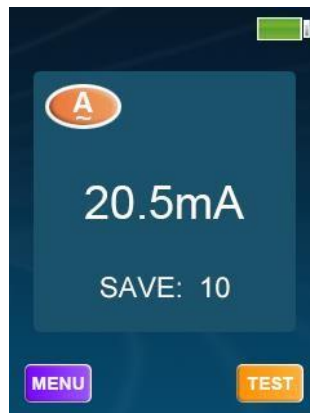

(5) Current measurement



(6) Selection method

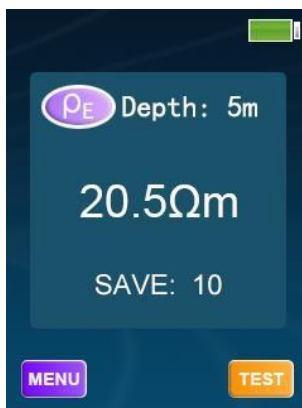

Based in New York City & Toronto, GAO Tek Inc. is ranked as one of the top 10 global B2B technology suppliers. GAO ships overnight within the U.S. & Canada & provides top-notch support thanks to its 4 decades of experience.

(7) Soil resistivity measurement (8) Data query interface (9) Alarm function interface

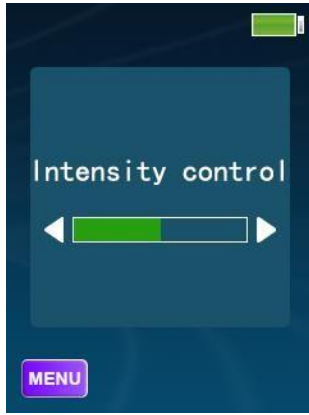

(10) Brightness setting interface

2 Interface icon symbol description

.  Jaw opening symbol, which is displayed when the jaw is opened. At this time, the trigger may be pressed artificially; or the jaws have been seriously contaminated, and the measurement cannot be continued.

.  Battery voltage low symbol, when the battery voltage is too low, this symbol is displayed. At this time, the accuracy of the measurement cannot be guaranteed, and the battery should be replaced.

. The "OL" symbol indicates that the measured value exceeds the measuring range of the clamp meter.

.  Alarm symbol. This symbol indicates that the alarm has been turned on. When the measured value is greater than or less than the set alarm threshold, the meter will emit an intermittent "beep--beep--beep--" sound.

.  Indicates that the clamp method is used to measure the resistance interface.

.  Indicates that the resistance interface is measured by the three-four-wire method.

.  Indicates the ground voltage measurement interface.



Indicates the AC current measurement interface.



Representation selection method measurement interface.



Indicates the soil resistivity measurement interface.



Indicates that the current data is held and saved

Measuring Principle

1 Principle of Clamp Method Resistance Measurement

The basic principle of the GAOTek Earth Resistance XDSL Tester is to measure the ground resistance is to measure the loop resistance. See below. The jaw part of the clamp meter is composed of a voltage coil and a current coil. The voltage coil provides an excitation signal and induces a potential V on the circuit under test. Under the action of the potential V , a current I will be generated in the circuit under test. The clamp meter measures I and calculates the measured resistance R .

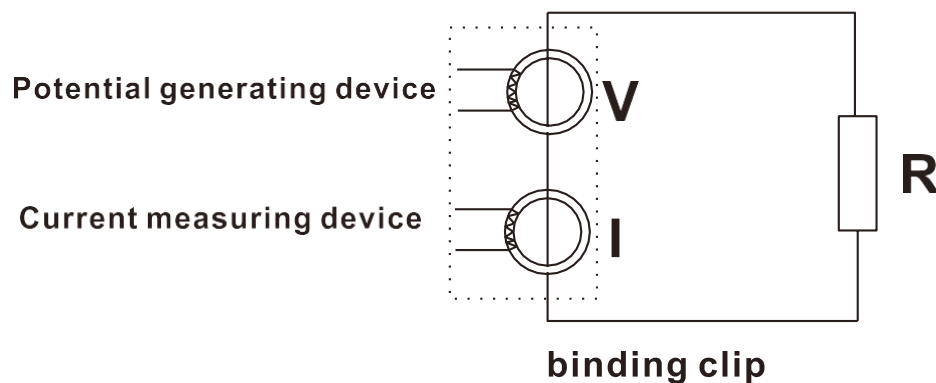

2 Three-four-wire method measurement principle

The three-wire four-wire method measures grounding resistance, which is suitable for accurately measuring single-point grounding systems. That is, the AC rated current I flows between the measuring object E ground electrode and the H current electrode, the potential difference V between the E ground electrode and the S voltage electrode is calculated, and the ground resistance value R is calculated according to the formula $R=V/I$. In order to ensure the accuracy of the test, the 4-wire method is adopted and the ES auxiliary ground electrode is added. In the actual test, ES and E are clamped on the same point of the grounding body.

Based in New York City & Toronto, GAOTek Inc. is ranked as one of the top 10 global B2B technology suppliers. GAOTek ships overnight within the U.S. & Canada & provides top-notch support thanks to its 4 decades of experience.

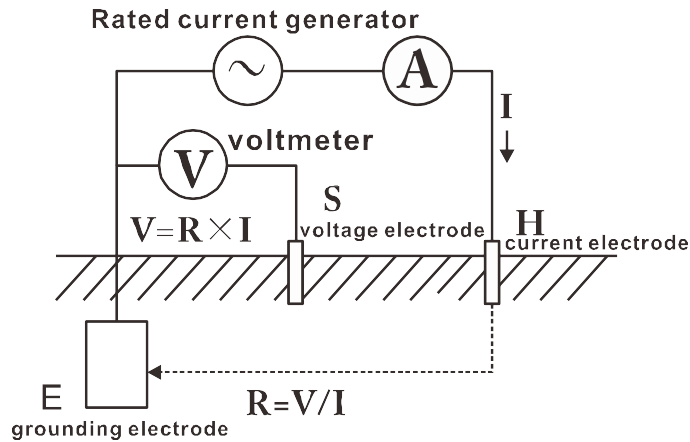

3 Selection method measurement principle

The selection method is used to measure the grounding resistance value, which is suitable for measuring the grounding resistance value of one of the parallel grounding systems without tripping. An alternating current I is applied between the ground electrode of **Re1 Re2 Re3** and the current electrode of **H**, the current I_3 flowing through **Re3** is measured by the current clamp **A**, and the potential difference V between the ground electrode of **Re3** and the voltage electrode of **S** is measured at the same time, and according to the formula $Re3= V/I_3$ calculates the grounding resistance value **Re3**. In order to ensure the accuracy of the test, the 4-wire method is adopted and the **ES** auxiliary ground electrode is added. In the actual test, **ES** and **E** are clamped on the same point of the grounding body.

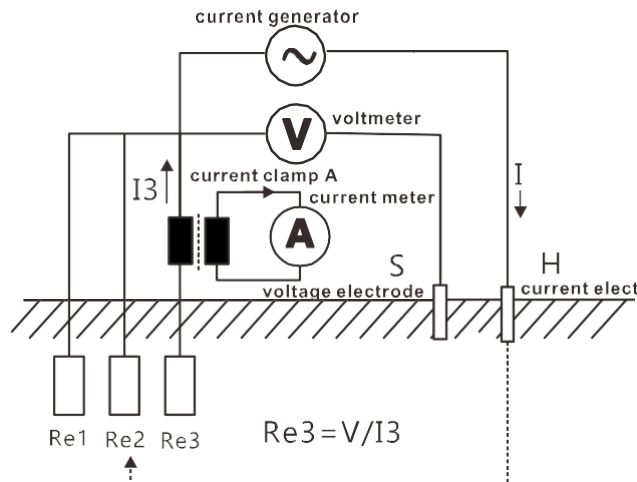

4 Principle of Soil Resistivity Measurement

The soil resistivity (ρ) is measured by the **4-pole method (Winner method)**: The alternating current I flows between the **E** ground electrode and the **H** current electrode, find the potential difference V between the **S** voltage electrode and the **ES** auxiliary ground electrode, The potential difference V is divided by the alternating current I to get the resistance value R at the middle two points, the electrode spacing distance is $a(m)$, according to the formula $\rho=2\pi aR(\Omega m)$ to get the value of soil resistivity, the distance between **HS** and **S-ES** When equal (both are a), it is Winner's method. For the convenience of calculation, please make the electrode spacing a far greater than the buried depth h . Generally, $a > 20h$ should be satisfied, as shown in the figure below.

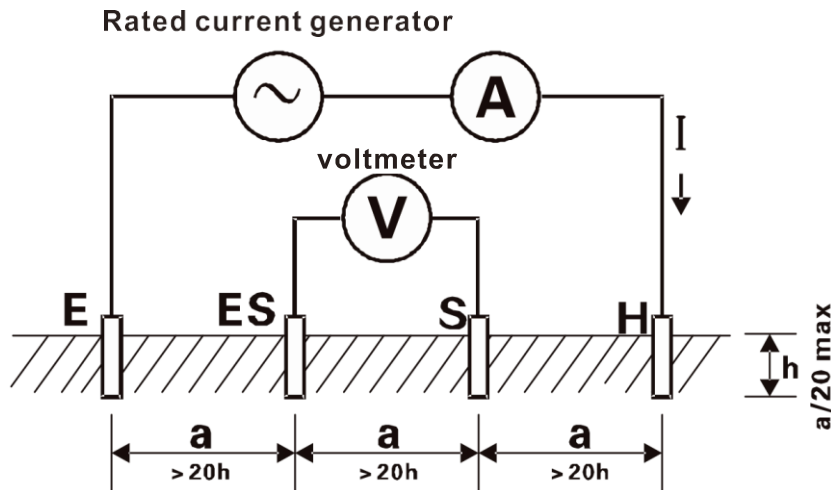

5 Working error principle

Among the above methods, the working error (**B**) is the error obtained within the rated working conditions, which is calculated from the inherent error (**A**) and variable error (**E_i**) of the instrument.

$$B = \pm (|A| + 1.15 \times \sqrt{E_2^2 + E_3^2 + E_4^2 + E_5^2})$$

A: Inherent error

E₂: Variation due to changes in power supply voltage

E₃: Variation due to temperature changes

E₄: Variation due to disturbance voltage changes

Based in New York City & Toronto, GAO Tek Inc. is ranked as one of the top 10 global B2B technology suppliers. GAO ships overnight within the U.S. & Canada & provides top-notch support thanks to its 4 decades of experience.



E5: Variation in contact electrode resistance

6 AC current measurement principle

True RMS measurement

7 Ground voltage measurement principle

Average measurement.

Operation Method

1 Switch machine

	Before starting up, press the trigger once or twice to make sure the jaws are well closed
	Do not apply external force to the jaws, otherwise the accuracy of the measurement cannot be guaranteed

Press the power button to switch the machine. It will automatically shut down after 15 minutes after it is turned on. Pressing any key will extend another 15 minutes.

2 Function selection

After the meter is turned on, it automatically enters the main menu interface, you can short press the ▲ or ▼ key to switch to the corresponding function, then short press the **TEST** key to enter the menu selection item, short press the **MENU** key to return to the main menu interface.

3 Clamp measurement

In the menu selection, select the "**clamp method**" function and press the **TEST** key to enter.

Check whether the meter displays "OL", then resistance measurement can be performed. Otherwise, you need to check whether the clamp head is tight.

Open the clamp head and clamp into the resistance circuit (make sure the clamp head is closed to ensure accuracy, otherwise you need to check whether the clamp head is closed.). Wait for the value to stabilize and read the displayed resistance value.

Short press the **TEST** key to keep the data and save it, the screen displays the "**HOLD**" icon, short press the **TEST** key again to cancel the hold state, the screen does not display the "HOLD" icon.

Short press the **MENU** button to return to the main menu.

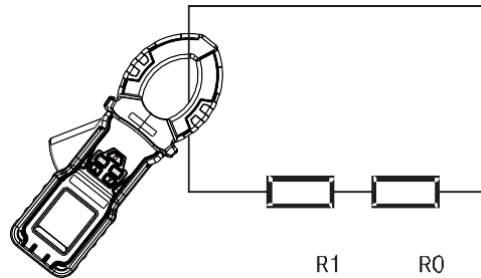

4 Three-four-wire method measurement

In the menu selection, select the "three-four-line" function and press the **TEST** key to enter.

Insert the test wire into the bottom port of the meter according to the color, as shown in the figure below. Wait for the value to stabilize, read the displayed resistance value

Short press the **TEST** key to keep the data and save it, the screen displays the "HOLD" icon, short press the **TEST** key again to cancel the hold state, the screen does not display the "HOLD" icon.

Press the **MENU** key to return to the main menu.

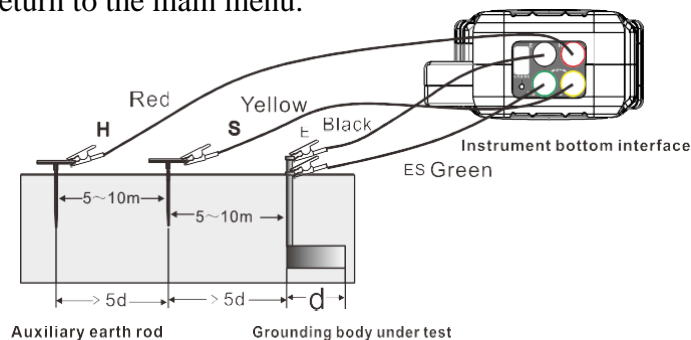

Fig. 8.4-2 Schematic diagram of four-wire measurement wiring

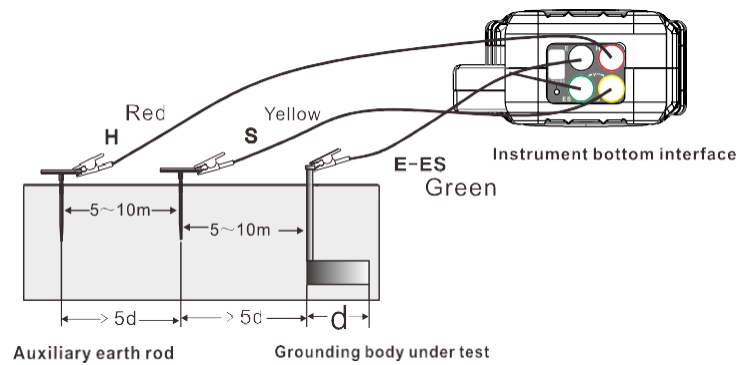

Fig. 8.4-2 Schematic diagram of three-wire measurement wiring

5 Ground voltage measurement

In the menu selection, select the "voltage measurement" function and press the **TEST** to enter.

Insert the test wire into the **S** and **ES** ports at the bottom of the meter, as shown in the figure below. Wait for the value to stabilize and read the displayed voltage value.

Press the **TEST** key to keep the data and save it, the screen displays the "**HOLD**" icon, short press the **TEST** key again to cancel the hold state, the screen does not display the "**HOLD**" icon.

Press the **MENU** key to return to the main menu.

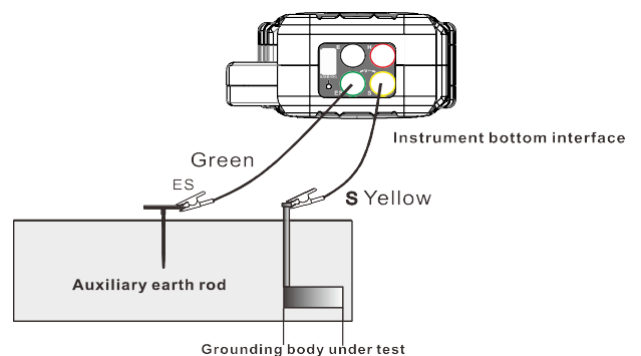

6 AC current measurement

In the menu selection, select the "current measurement" function, press the **TEST** key to enter.

Open the clamp head and clamp the wire under test. Wait for the value to stabilize and read the displayed current value.

Based in New York City & Toronto, GAO Tek Inc. is ranked as one of the top 10 global B2B technology suppliers. GAO ships overnight within the U.S. & Canada & provides top-notch support thanks to its 4 decades of experience.

Short press the **TEST** key to keep the data and save it, the screen displays the **"HOLD"** icon, short press the **TEST** key again to cancel the hold state, the screen does not display the **"HOLD"** icon.

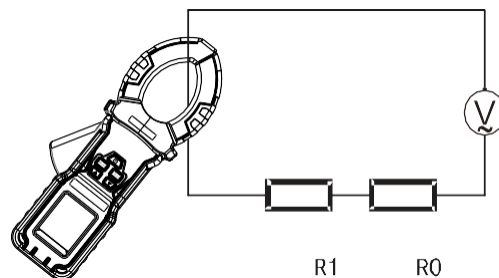

Press the **MENU** key to return to the main menu.

7 Selection method

- 1) In the menu selection, select the **"selection method"** function and press the **TEST** key to enter.
- 2) Insert the test wire into the bottom port of the meter according to the color, as shown in the figure below. Then open the clamp head and clamp into the resistance circuit. Wait for the value to stabilize and read the displayed current value.
- 3) Press the **TEST** key to keep the data and save it, the screen displays the **"HOLD"** icon, short press the **TEST** key again to cancel the hold state, the screen does not display the **"HOLD"** icon.
- 4) Press the **MENU** key to return to the main menu.

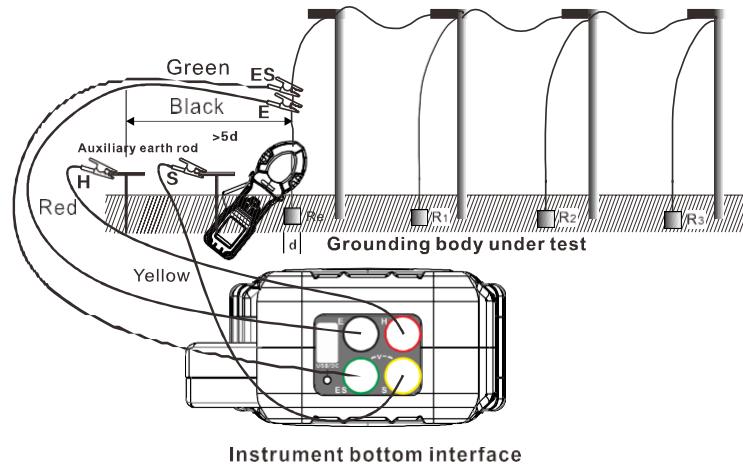

8 Soil resistivity measurement

- 1) In the menu selection, select the **"Soil resistivity measurement"** function and press the **TEST** to enter.
- 2) After entering the soil resistivity test interface, the upper right corner of the LCD displays the current depth value. The depth value can be modified by short pressing the ▲ key to decrease 1 or short pressing the ▼ key to increase 1 step. Or long press ▲ key to decrease 10 or long press ▼ key to increase 10 steps to modify the depth value. The depth value range can only be 1m~100m.
- 3) Insert the test wire into the bottom port of the meter according to the color, as shown in the figure below. Wait for the value to stabilize and read the displayed resistance value.
- 4) Press the TEST key to keep the data and save it, the screen displays the "HOLD" icon, short press the TEST key again to cancel the hold state, the screen does not display the "HOLD" icon.
- 5) Press the **MENU** key to return to the main menu.

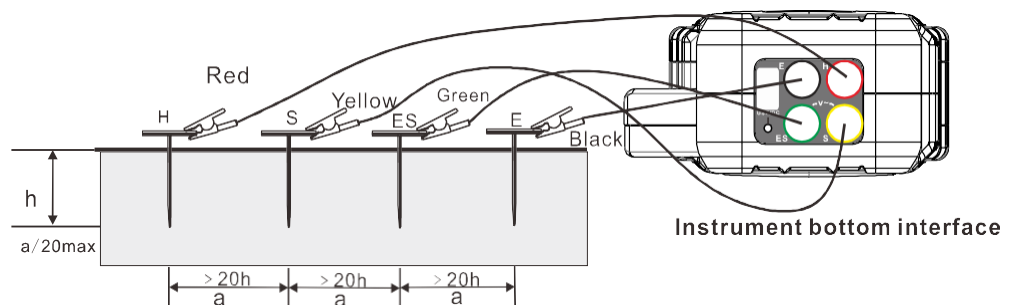

Based in New York City & Toronto, GAO Tek Inc. is ranked as one of the top 10 global B2B technology suppliers. GAO ships overnight within the U.S. & Canada & provides top-notch support thanks to its 4 decades of experience.

8 Data query and deletion

In the menu selection, select the "Data query" function and press the **TEST** to enter.

The stored data can be viewed in steps by pressing the ▲ key to subtract 1 or short pressing the ▼ key to increase 1 step.

Or by long pressing the ▲ key to decrease 10 or long pressing the ▼ key to increase 10 steps to view the stored data.

Press the **TEST** key to enter the delete mode, then press the ▲ key to confirm the deletion of the data, or press the ▼ key to cancel the deletion of the data.

Press the **MENU** key to return to the main menu.

9 Alarm Settings



In the menu selection, select the "alarm function" function, press the **TEST** key to enter

The alarm thresholds for four measurement functions can be set.



After entering the alarm function interface, you can switch the set alarm type by short pressing the ▲ key or the ▼ key.

After confirming the alarm type, short press the **TEST** key to enter the alarm state selection, and then short press the ▲ key or the ▼ key to switch between setting greater than alarm (>) or less than alarm (<).

After confirming the alarm status, you can short press the **TEST** key to enter the alarm threshold modification status, short press the ▲ key to decrease the step or short press the ▼ key to increase the step to modify the threshold.

Long press the ▲ key to move the threshold step cursor to the right, and long press the ▼ key to move the threshold step cursor to the left.

Short press the **TEST** key again to save the current settings and exit.

Or short press the **MENU** key to return to the previous layer, short press the MENU key in the layer where the alarm type is selected to return to the menu interface.

Long press the MENU button on any interface to enable or disable the alarm function.

X. Battery Instructions

When the battery voltage is too low, the battery symbol "" is displayed, please charge it in time.

Low battery voltage affects measurement accuracy

When the boot screen flashes, the screen goes black. It may be that the battery power is not enough to boot. Please charge it fully before starting measurement.

The battery symbol "" flashes to indicate that it is about to be shut down, and the test cannot be performed at this time. Please fully charge the battery and start the test again.

Mobile APP Instructions

After installing the APP of "Earth Resistance XDSL Tester. apk" in the CD, open the APP to search for a Bluetooth device named "CLAMP_METER" (This function can only be used for devices with Bluetooth), click it and wait for successful connection (Bluetooth PIN code: 123456 is required for the first connection).



If the mobile phone is connected to the instrument through Bluetooth, the software on the computer side will not be connected. If you need to use the software on the computer side, please disconnect the Bluetooth connection on the mobile phone before using it.

After successful connection, it can operate test and display online, browse history storage data, and set alarm value.

Field Application

1 Multi-point grounding system

For multi-point grounding systems (such as power transmission system tower grounding, communication cable grounding systems, certain buildings, etc.), they are connected by overhead ground wires (the shielding layer of communication cables) to form a grounding system. See below. When measuring with a clamp meter, its equivalent circuit is as follows:

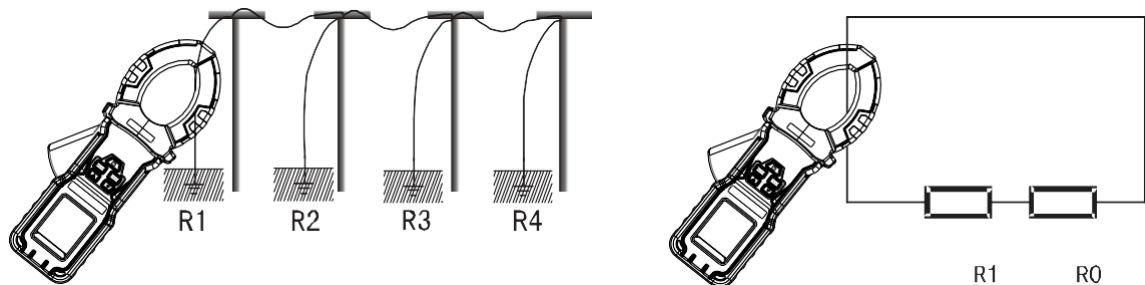

R1 is the predicted grounding resistance.

R0 is the equivalent resistance of the grounding resistance of all other towers in parallel.

Although, from the strict grounding theory, due to the existence of the so-called "mutual resistance", R0 is not a parallel value in the usual electronic technical sense (it will be slightly larger than the parallel value in the electronic technical sense), but, Since the grounding hemisphere of each tower is much smaller than the distance between the towers, and after all, the number of grounding points is large, R0 is much smaller than R1. Therefore, it is reasonable to assume $R0=0$ from an engineering perspective. In this way, the resistance we measured should be R1.

Based in New York City & Toronto, GAO Tek Inc. is ranked as one of the top 10 global B2B technology suppliers. GAO ships overnight within the U.S. & Canada & provides top-notch support thanks to its 4 decades of experience.



Several comparative experiments with traditional methods under different environments and different occasions prove that the above assumptions are completely reasonable.

2. Limited point grounding system

This situation is also more common. For example, some poles and towers are connected to each other by overhead ground wires; for example, the grounding of some buildings is not an independent grounding network, but several grounding bodies are connected to each other through wires.

In this case, if R_0 in the above figure is regarded as 0, it will bring a large error to the measurement result.

For the same reason as above, we ignore the influence of mutual resistance, and calculate the equivalent resistance after the parallel connection of the grounding resistance in the usual sense. In this way, for a grounding system with N (N is small, but greater than 2) grounding bodies, N equations can be listed:

$$R_2 + \frac{1}{\frac{1}{R_1} + \frac{1}{R_3} + \dots + \frac{1}{R_N}} = R_{2T}$$

$$R_N + \frac{1}{\frac{1}{R_1} + \frac{1}{R_2} + \dots + \frac{1}{R_{(N-1)}}} = R_{NT}$$

R_1, R_2, \dots, R_N are the grounding resistances of N grounding bodies we require.

$R_{1T}, R_{2T}, \dots, R_{NT}$ are the resistances measured on each grounding branch with clamp meter.

This is a nonlinear equation system with N unknowns and N equations. It has a definite solution, but it is very difficult to solve it manually, even impossible when N is large. To this end, please purchase our company's limited point grounding system solution program software, and users can use office computers or laptop computers for machine solution. In principle, in addition to ignoring the mutual resistance, this method does not have the measurement error caused by ignoring R_0 . However, the user needs to pay attention to: In your grounding system, if there are

Based in New York City & Toronto, GAO Tek Inc. is ranked as one of the top 10 global B2B technology suppliers. GAO ships overnight within the U.S. & Canada & provides top-notch support thanks to its 4 decades of experience.

several grounding bodies connected to each other, you must measure the same number of test values for the program to solve, not more or less. The program also outputs the same number of ground resistance values

3. Single point grounding system

From the principle of testing, the clamp meter can only measure loop resistance, but cannot measure single-point grounding. However, users can use a test wire and a ground electrode near the grounding system to artificially create a loop for testing. The following introduces two

methods for measuring single-point grounding with a clamp meter. This method can be applied to occasions where the traditional voltage-current method cannot be tested.

4. Two-point method

As shown in the figure below, find an independent grounding body RB with good grounding near the tested grounding body RA (such as nearby water pipes, buildings, etc.). Connect RA and RB with a test wire.

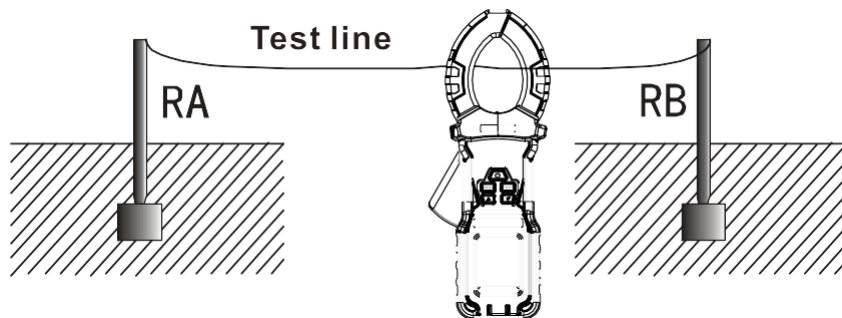

Because the resistance measured by the clamp meter is the series value of two grounding resistances and the resistance of the test line.

$$R_T = R_A + R_B + R_L$$

R_T is the resistance measured by the clamp meter.

R_L is the resistance of the test line

Therefore, if the measured value of the clamp meter is less than the allowable value of grounding resistance, then the grounding resistance of the two grounding bodies is qualified.



5. Three-point method

As shown in the figure below, find two independent grounding bodies RB and RC near the tested grounding body RA.

The first step is to connect RA and RB with a test line, as shown in the figure below. Use the clamp meter to read the first data R1.

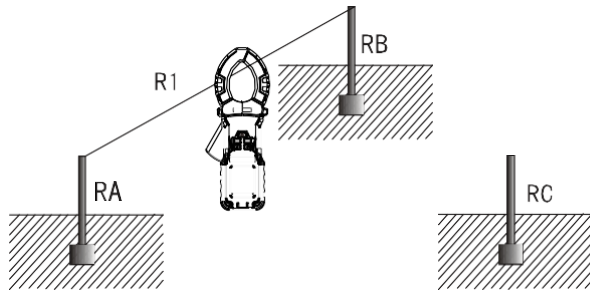

The second step is to connect RB and RC, as shown in the figure below. Use the clamp meter to read the second data R2.

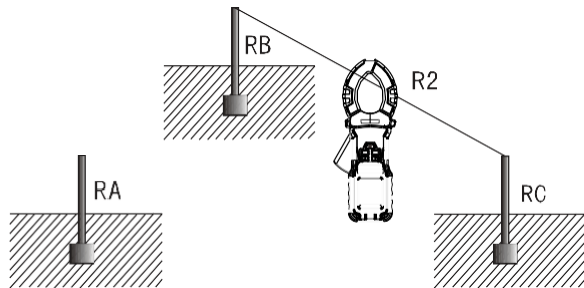

The third step is to connect RC and RA, as shown in the figure below. Use the clamp meter to read the third data R3.

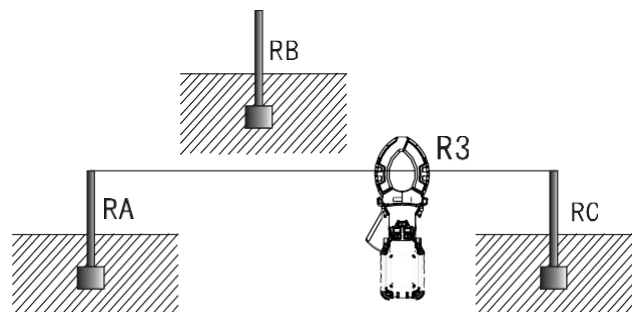

In the above three steps, the readings measured in each step are the series value of two grounding resistances. In this way, you can easily calculate each ground resistance value:

Based in New York City & Toronto, GAO Tek Inc. is ranked as one of the top 10 global B2B technology suppliers. GAO ships overnight within the U.S. & Canada & provides top-notch support thanks to its 4 decades of experience.



because of: $R1=RA+RB$ $R2=RB+RC$ $R3=RC+RA$

So: $RA= (R1+R3-R2) \div 2$

This is the ground resistance value of the grounding body RA. In order to facilitate the memorization of the above formula, the three grounding bodies can be regarded as a triangle, and the measured resistance is equal to the adjacent side resistance plus the opposite side resistance divided by 2.

The ground resistance values of the other two grounding bodies as reference objects: $RB=R1-RA$ $RC=R3-RA$

Packing List

Meter	1 pcs
Test line	4 pcs
Simple test line	2 pcs
USB communication line	1 pcs
Charger	1 pcs
Monitoring software CD	1 pcs
Instructions, warranty	1 set
Instrument box	1 pcs

The content of this user manual cannot be used as a reason for using the product for special purposes.

The company is not responsible for other losses caused by use.

The company reserves the right to modify the contents of the user manual. If there are changes, no further notice will be given.

Based in New York City & Toronto, GAO Tek Inc. is ranked as one of the top 10 global B2B technology suppliers. GAO ships overnight within the U.S. & Canada & provides top-notch support thanks to its 4 decades of experience.



Contact us: sales@gaotek.com

Based in New York City & Toronto, GAO Tek Inc. is ranked as one of the top 10 global B2B technology suppliers. GAO ships overnight within the U.S. & Canada & provides top-notch support thanks to its 4 decades of experience.