



Product Name	GAOTek Thermal payloads Camera Drones
Product SKU	GaoTek-PD-215
Product URL	https://gaotek.com/product/gaotek-long-distance-payload-cargo-quadcopter-drone/

Contact us: sales@gaotek.com

Based in New York City & Toronto, GAO Tek Inc. is ranked as one of the top 10 global B2B technology suppliers. GAO ships overnight within the U.S. & Canada & provides top-notch support thanks to its 4 decades of experience.



Table of Contents

1.Disclaimer	3
2 The composition of the remote control model and its representative meaning	4
3.Download software and real-name authentication steps.....	8
4. Battery and charger operation training	8
5. Introduction of various spare parts of the drone and explanation of error-prone points	11
6.Training on remote control calibration, accelerometer calibration, GPS calibration operation	13
6.1 Calibration of remote control.....	13
7.Training on drone motor startup and shutdown operation.....	16
8.Detailed operation of drone plot planning	16
9.Obstacle avoidance radar on and off.....	18
10.Training on loss of control protection settings.....	18
11.Training on parameter setting explanation in the spray setting	18
12.Explanation and training of maximum flight speed, return altitude, course speed, work completion behavior, U-turn, and nose orientation while return	18
13.Flight operation procedures and precautions	19
14.Explanation and training of voltage setting of battery primary alarm and secondary alarm... 21	
15.How to manually take over operation after out-of-control protection, pesticide off protection, and work completion execution	22
16.Safe flight precautions	22
17. Safe operation precautions.....	24
18. List of dangers and hazards and solutions	29
19.Installation troubleshooting	34
20.Package and transport	36
21.Cleaning and maintenance requirements	36
22.Pesticide use regulations	37



GAOTek Thermal payloads Camera Drones

1.Disclaimer

This product is not a toy and is not suitable for use by people under age of 18. Keep this product away from children. Before using this product, please read the Product Manual carefully. This disclaimer has great significance for the safe use of the product and your legal rights and interests. Be sure to read this document carefully before using the product to understand your legal rights, responsibilities, and safety instructions. Otherwise, property damage, accidents, and safety risks may occur. By using this product, you are deemed to have understood, approved and accepted all terms and contents of this document.

Users undertake to use the Product only for legitimate purposes and agrees to these Terms and any related policies or guidelines TYI may establish. TYI makes no warranties of any kind, express or implied, with respect to the Products, including, without limitation, implied warranties of marketability, fitness for a particular purpose or non-infringement. To the fullest extent permitted by law, you (and not TYI) bear all costs for all necessary services, repairs, and corrections. TYI shall not be liable for any loss caused by the user's failure to use the Product in accordance with this document and the Product User Manual. TYI shall not be liable for any indirect, consequential, punitive, accidental, special or penal damage, including any loss caused by your purchase, use or inability to use the Product (even if TYI has been advised of the possibility of such losses). To the fullest extent permitted by law, TYI's total legal liability to you (whether contractual or otherwise) for all damages, losses and resulting litigation will not, in any event, exceed the amount you paid TYI for the products, if any.

In compliance with laws and regulations, TYI has the right to the final interpretation of the above terms. TYI has the right to update the contents of this precautions without prior notice. This note shall be valid for a long time before revision or termination.

Based in New York City & Toronto, GAO Tek Inc. is ranked as one of the top 10 global B2B technology suppliers. GAO ships overnight within the U.S. & Canada & provides top-notch support thanks to its 4 decades of experience.



This manual may not be copied, stored in a database, or otherwise disclosed in any form without permission. Use of this manual without permission of the company is an infringement and will be prosecuted for legal liability.

This product manual is only for users to refer to, and shall not be used as the basis of whether the product is qualified or not or for other legal decisions. This product is only used for agricultural, and shall not be used for other purposes or illegal activities. The operator shall abide by the relevant laws and regulations of the People's Republic of China to operate the drone in accordance with the law. The operator's failure to operate as required by laws and regulations of the People's Republic of China has nothing to do with the Company.

2.The composition of the remote-control model and its representative meaning

Note:

Failure to follow the instructions may result in property damage and injury. Failure to follow the instructions may result in property damage, major accidents, and serious injuries. Take off and landing steps

2.1. Take off: The operator stands 8 meters away from the tail of the drone – perform a Combination Stick Command (CSC) to unlock the motor -- gently pushes the left control lever upward (American hand) -- and takes off.



Based in New York City & Toronto, GAO Tek Inc. is ranked as one of the top 10 global B2B technology suppliers. GAO ships overnight within the U.S. & Canada & provides top-notch support thanks to its 4 decades of experience.

2.2. **Landing:** The operator stands 8 meters away from the tail of the drone -- gently push down the left control lever (American hand) -- when the drone lands on the ground -- push down the left control lever (American hand) for 5 seconds until the motor (propeller) stops working.

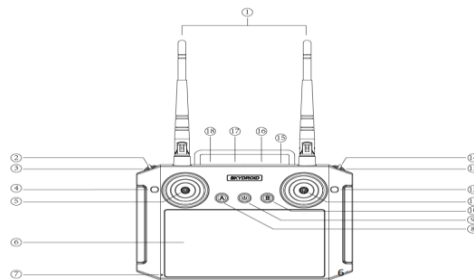

Safe landing steps: Agricultural drone needs to land away from people. Packing to prevent damage to agricultural drones during transportation. Place the drone in a dry and ventilated place (place high to prevent children from touching)

Meaning of each key



Note: The antenna of the remote control should be opened at a 45 degree angle durin

No	Meaning	No	Meaning
1	2.4G 3d bantenna	10	AB modes
2	Height-location-automatic	11	Stick X2 (left and right), Y2 (front and back
3	Thumb wheel G(two-axis camera control)	12	Independent key
4	Seeding switch	13	Thumb wheel H
5	Stick X1 (rotate), Y1 (up and down)	14	Return flight
6	5.5-inch screen	15	Loud speaker
7	MIC interface	16	SIM card slot
8	Water pump	17	Charging port
9	Power switch	18	PPM output

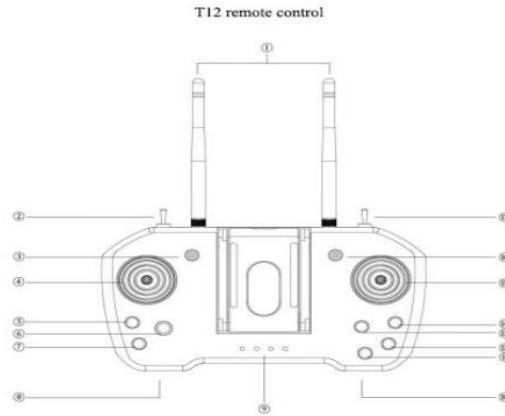

Meaning of each key

No	Meaning	No	Meaning
1	2.4G 3dB bantenna	10	USB2/charge/data transmission
2	Return flight	11	Key D
3	Height-location-automatic	12	Key C
4	Left stickX1、 Y1	13	Seeding switch
5	Reserved switch (no function yet)	14	Key B
6	Two-axis camera control	15	Right stick X2、 Y2
7	Power switch	16	AB modes
8	USB1/Image output	17	Water pump
9	Power switch		

Note: Open the antenna of the remote control T12 at a 45 degree angle during flight.

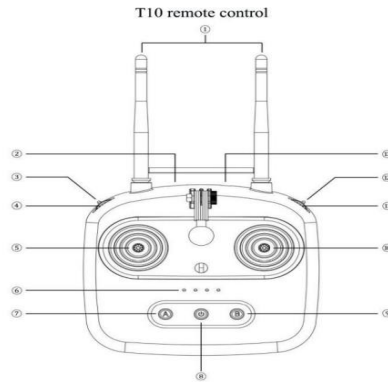

Meaning of each key

Note: Open the antenna of the remote control T10 at a 45 degree

No	Meaning	No	Meaning
1	2.4G 3dB bantenna	8	On-off key
2	USB/Image output	9	AB modes
3	Height-location-automatic	10	Right stick X2、 Y2
4	Two-axis camera control	11	Thumb wheel D
5	Left stick X1、 Y1	12	Return flight
6	Power indicator light	13	USB2/charge/data transmission
7	Water pump		



3. Download software and real-name authentication steps

Take out the Android phone -- find the software Housekeeper -- scan the QR code of the APP-- download and install the "Agr assistant" APP.

Open the "Agr assistant" APP -- select "Register" -- enter the mobile phone number, and verification code enter the password to be set -- click confirm -- re-enter the mobile phone number, and login password -- click confirm -- select the bottom right "My" -- select "Real-name authentication" -- enter the real name, ID number -- upload ID photo -- upload handheld ID photo -- click submit -- wait for approval (Note: Use only after approval)

4. Battery and charger operation training

4.1 Charge and power check steps:

Take out the charger -- plug the charger into the household 220V power socket -- open the charger -- the charger is set to charge mode -- set the charging current -- take out the battery -- connect the power interface and the charger charging connector -- connect the balanced interface and the balanced interface of the charger -- long-press the "Start" button for three seconds -- start charging -- remove the battery after it is full -- press the power switch on the smart battery -confirm the battery power through the indicator light.

4.2 Precautions for the safe use of smart batteries:

Customer storage:

- 1) The battery can not be placed in direct sunlight and an outdoor sealed compartment environment, the temperature in the compartment is prone to reach more than 60°C.
- 2) During outfield downtime, the battery needs to be taken off and placed in the shade. Support multiple devices to be added at the same time, simplify the tedious steps of network configuration, and make the device networking operation more user-friendly;

Based in New York City & Toronto, GAO Tek Inc. is ranked as one of the top 10 global B2B technology suppliers. GAO ships overnight within the U.S. & Canada & provides top-notch support thanks to its 4 decades of experience.



- 3) Do not charge or discharge when battery is deformed, bloating, or water intake and store it in isolation.
- 4) If the battery is not used for a long time, separate the battery from the device to avoid over discharge caused by device power consumption.
- 5) Battery storage must be kept away from combustible materials, such as oil-fired generators.
- 6) No direct sunlight or rain leakage, wet environment.

Professional storage:

- 1) After the battery is off the machine, it cannot be charged immediately. The surface temperature of the battery should drop to 45°C or normal temperature before charging.
- 2) The battery cannot be charged if it is swollen (expansion rate > 8%), deformed, damaged in appearance, or the minimum voltage of a cell is less than 2.75V.
- 3) Someone must monitor during charging and maintenance, and no flammable objects, such as fuel generators, can be stored within 1 meter of charging.
- 4) Connect the charger socket with 3C certified 16A socket.
- 5) In winter environment, use slow charging mode, charging current < 5A.
- 6) Battery overcharge standard: single voltage > 4.25V.

4.3. Precautions for batteries:

- 1) Do not use in high temperature environment, battery temperature > 45°C is not allowed to be used in drone.



- 2) After the battery is hit, there will be deformation and dents. It is strictly forbidden to charge or continue to use. Store it in a separate open place after the mark.
- 3) Battery with large pressure difference is prohibited from flying (full voltage difference > 100mV or half voltage difference > 150mV is judged as large pressure difference).
- 4) In winter environment, it needs to be warmed up before flying, the propeller on the ground is idling for half a minute, hover for 10 seconds before taking off.
- 5) It is necessary to control the uniform speed, and it is not suitable to do rapid climbing.
- 6) Non-professionals should not disassemble the battery, it may cause internal short circuit, gas blowing, fire and other problems.
- 7) After spraying, if there are pesticides or accumulated water on the battery cover, do not put the cover on the plug to avoid short circuit of the battery or corrosion of the plug by the pesticide.
- 8) When the battery plug is connected with the drone end and the charger end connector, they must be inserted in parallel, and the oblique insertion may cause the connector to catch fire.
- 9) For batteries with a charging balance port, the silicone sleeve of the balance block should be tightly covered after charging to prevent pesticides from entering the balance port and corroding the plug.
- 10) When lifting the battery, the battery handle should be lifted. Do not lift the power cord.
- 11) It is forbidden to stack, randomly place or pile up batteries, keep away from power sources and other flammable objects.
- 12) When the battery is charging, it is forbidden to be near the bed, closet and other flammable objects.
- 13) It is forbidden to plug multiple chargers into one power strip to charge the battery.
- 14) Battery storage and maintenance should be carried out during vacation or when the battery is not used for a long time.

Based in New York City & Toronto, GAO Tek Inc. is ranked as one of the top 10 global B2B technology suppliers. GAO ships overnight within the U.S. & Canada & provides top-notch support thanks to its 4 decades of experience.



- 15) The battery storage area should be equipped with a dry powder or water-based extinguisher and a bucket of sand.
- 16) When the battery is not used for a long time, it is necessary to store and maintain the battery regularly, at least once every two months.
- 17) Damaged batteries should be stored separately from other batteries to avoid spontaneous combustion.
- 18) Battery plugs should be cleaned often with alcohol to avoid excessive dust resulting in poor contact.
- 19) The place where the battery is stored should be ventilated and dry. A humid environment may cause patina to appear inside the battery and lead to poor contact.
- 20) The battery must not be pierced with a metal object, otherwise it may cause the battery to catch fire.
- 21) Discarded batteries should be soaked in an appropriate concentration of salt water for more than 48 hours.

4.4. For details, refer to the manual in the charger (model)packing box

5. Introduction of various spare parts of the drone and explanation of error-prone points

- 5.1 The GPS should be erected and fastened tightly, and the arrow of the GPS should face the front of the drone.
- 5.2 The propeller is unfolded into a horizontal state, the tightness of the propeller and the forward and reverse explanation.

Based in New York City & Toronto, GAO Tek Inc. is ranked as one of the top 10 global B2B technology suppliers. GAO ships overnight within the U.S. & Canada & provides top-notch support thanks to its 4 decades of experience.



5.3 Whether the motor rotation is normal, whether there is any noise.

5.4 The sleeve of the folding part should be tightened.

5.5 The silicone sleeve of the air inlet hole of the pesticide box cover needs to be opened.

5.6 How to discharge the air from the nozzle; (turn on the black pressure relief valve next to the nozzle of the pump switch and loosen). 5.7 When using the AS150 plug, explain the plug-in sequence (connect the black plug first and then the red plug).

6. Training on remote control calibration, accelerometer calibration, GPS calibration operation

6.1 Calibration of remote control

Turn on the remote control—power on the drone, put it in a horizontal position and keep still—open the "Agr assistant" APP—click to execute work—click "..." in the upper right corner—click the remote-control icon—click the remote control to calibrate—click to start calibration—turn the two control levers of the remote control back and forth, left and right, for 2 circles to reach the maximum travel position, and toggle the two toggle switches back and forth twice—click to complete the calibration.

6.2 Calibration of accelerometer

Turn on the remote control—power on the drone, put it in a horizontal position and keep still—open the "Agr assistant" APP—click "Please connect the device"—click "H12/MK15"—click "OK"—click "Execute work " - click on the upper right corner "..." - click on the drone icon - click on sensors - click on accelerometer calibration - wait for the calibration to complete (and click to complete).



6.3 GPS calibration

- 1) Turn on the remote controller—power on the drone, and put it in a horizontal position to stay still.
- 2) Click to enter the "Agr assistant " APP, click "Execute Operation", click the three dots in the upper right corner, click the drone icon, - click the sensor, click "Magnetic Compass Calibration", click "Start Calibration".
- 3) At this time, the LED light of the drone is steady yellow. Two people lift the drone, take the center of the drone as the center, and rotate horizontally for 3 circles until the LED light turns green.
- 4) Two people lift the drone, take the center of the drone as the center, turn the nose down, and rotate vertically for 3 circles until the LED indicator light turns green and flashes; at this time, the GPS calibration is successful.

6.4 Under what circumstances does the drone need to recalibrate the compass

For the first use, the compass must be calibrated, otherwise the system may not work properly, which will affect flight safety. The compass is easily disturbed by strong electric fields, strong magnetic fields, and strong electromagnetic fields, which will cause abnormalities of the compass and even cause flight accidents. Frequent calibration can make the compass work at its best.

Calibration precautions

- 1) Do not calibrate in areas with strong magnetic and electric fields or near large pieces of metal, such as magnetic mines, parking lots, construction areas with underground steel bars, etc.
- 2) Do not carry ferromagnetic materials with you during calibration, such as keys, watches, etc.
- 3) Do not calibrate the compass indoors.
- 4) Do not calibrate near large pieces of metal.

Calibration steps

Based in New York City & Toronto, GAO Tek Inc. is ranked as one of the top 10 global B2B technology suppliers. GAO ships overnight within the U.S. & Canada & provides top-notch support thanks to its 4 decades of experience.

Please choose an open field and calibrate the compass according to the steps below. To see more about compass calibration, please watch the relevant instructional video.

Method: use the remote control (take the T12 remote control receiving system as an example).

- 1) Turn on the remote control, supply power to the drone, and quickly toggle back and forth 5-7 times between the attitude, GPS and AB operation of the mode switch of the remote control, the drone status indicator light, the yellow light is always on and enters the compass calibration state.
- 2) Take the nose as the center, rotate the drone horizontally for 2 turns, and the status light of the drone is steady green.
- 3) Make the drone nose down, rotate 2 circles horizontally, and place on the ground after the green light is extinguished.
- 4) The drone status indicator mode light flashes green quickly, and the calibration is completed. If the drone status indicator light flashes red, it means the calibration failed, please re-calibrate the compass

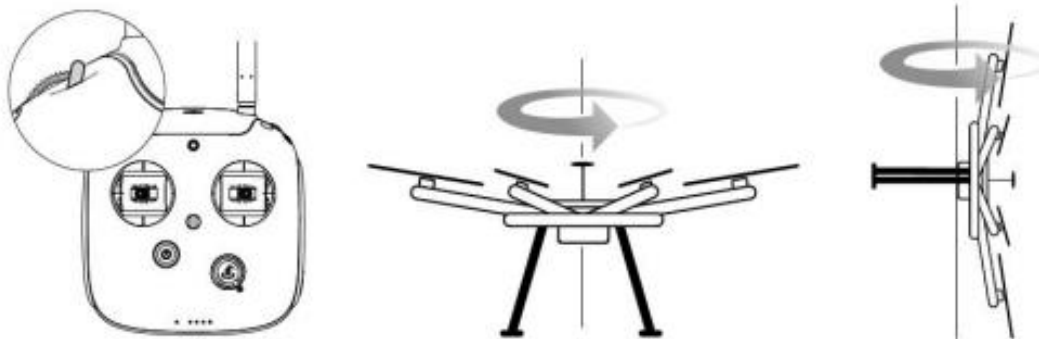

Conditions that require recalibration

- 1) The compass data is abnormal, and the drone status indicator light flashes red and yellow alternately.
- 2) The flight site is far from the site where the compass was last calibrated.



- 3) The mechanical structure of the drone has changed.
- 4) Drift is serious when flying, or it cannot fly in a straight line.
- 5) The compass needs to be recalibrated after the drone is repaired.

7. Training on drone motor startup and shutdown operation

Turn on the remote control—power on the drone, put it in a horizontal position and keep still—open the "Agr assistant" APP—click "Please connect the device"—click "H12/MK15"—click "OK"—click "Execute work"—Check the power of the drone—Check the power of the remote controller—Check the number of GPS satellites—Check whether the LED light is green—The operator stands at a position 8 meters away from the tail of the drone—perform a Combination Stick Command (CSC) to unlock the motor —Take off : Push the throttle up with the left hand, and the drone flies up—Landing: Pull the throttle down with the left hand, and the drone flies down;—Flight: Press the joystick with the left hand to the left, and the drone will rotate to the left on the spot; press the joystick to the right with the left hand, and the drone will rotate to the right on the spot; —Push the joystick up with the right hand, and the drone flies forward; pull down the joystick with the right hand, and the drone flies backward; —Press the joystick with the right hand to the left, and the drone will fly sideways; press the joystick with the right hand, and the drone will fly sideways to the right.—Hovering: When the left and right joysticks do not move, the drone will hover on the spot.

8. Detailed operation of drone plot planning

Open the phone's "Agr assistant" APP—click on the planning plot—click on adding a plot—click on (GPS) management—input the name of the plot—click on "Finish"—click on "OK"—pull the remote control to attitude (manual) Mode—place all joysticks in the middle—after confirming that the surrounding environment is safe — perform a Combination Stick Command (CSC) to take off —After operating the agricultural drone to the border point of the farmland—click on the border point—add No. 1 border point—there will be a voice prompt to add the border point successfully—

Based in New York City & Toronto, GAO Tek Inc. is ranked as one of the top 10 global B2B technology suppliers. GAO ships overnight within the U.S. & Canada & provides top-notch support thanks to its 4 decades of experience.



continue to fly to the inflection point of the agricultural field—click on the border point to add No. 2 border point —add at least three boundary points—after adding several boundary points in sequence—Note that after the agricultural drone hovers smoothly, click on the boundary point—click to save—determine the actual position of the boundary point —it can be obtained in real time through the camera module in the lower left corner of the APP—in this way, the position error when the boundary point is marked can be reduced—such as there are obstacles in the work field—click on the obstacle point—Choose to add polygonal obstacle points or circular obstacle points—Take polygonal obstacle points as an example—Operate the agricultural drone to make dots around obstacles—Click save after the dots are completed—Land the drone to a safe location—In my place Click on the plot, and there will be an edit plot - click to edit the plot map selection point—Choose to add polygonal obstacle points or circular obstacle points—Take polygonal obstacle points as an example—Operate the agricultural drone to make dots around obstacles—Click save after the dots are completed—Land the drone to a safe location—In my place Click on the plot, there will be an edit plot—click to edit the plot map to select points—Select boundary points and obstacle points—Adjust the position of boundary points—After adjusting the radius and position of obstacle points—Click OK—Choose to over write the original plot or save a new plot—Overwrite the original location Block - save - select the plot - click on the task assignment in the lower right corner - confirm the crop type (corn, rapeseed or other)—Route type(select land)—Back to the main interface—Click to execute the operation—Click on the task data—Find the land just allocated in the pending work—Click on the task—The yellow circle on the right side of the interface can be adjusting the angle of the flight path - and the takeoff and landing points of the agricultural drone to take off and spray—click on the route adjustment—you can set the operation interval—refer to the normal operation process—the distance between each route—click the plus and minus symbols—you can increase and decrease the distance between routes—increase the route —adjust the distance from the route to the boundary line —Indent the unilateral route—Indent the full route—Obstacle Margin—the distance between the route and the obstacle. Click the plus and minus symbols—you can increase or decrease the distance from the route to the obstacle—Route fine-tuning—the route fine-tuning is adjusted for the entire operation area—the operation area can be adjusted by moving up, down, left, and right—After the route data

Based in New York City & Toronto, GAO Tek Inc. is ranked as one of the top 10 global B2B technology suppliers. GAO ships overnight within the U.S. & Canada & provides top-notch support thanks to its 4 decades of experience.



parameters are adjusted—Confirm the settings—Click on the execution job in the lower right corner—Jump out a bullet box—Set flight parameters Spray mode—Select linkage spray in the spray mode—Water pump opening—Flight speed can be adjusted from 1m/s to 10m/s—Terrain following button is turned on— Terrain imitation height—Can be set from 3m to 10m— Coordinated turn button is turned on—Click OK after setting — Uploading waypoints — After 100% enter the pre-operation self-inspection interface—Self-inspection before operation to check the GPS signal—Magnetic compass accelerometer and take-off altitude information—After confirming that everything is normal—Slide to the right—The drone will automatically unlock and take off, execute the established route.

9.Obstacle avoidance radar on and off

Turn on the remote control—power on the drone, put it in a horizontal position and keep still— open the "Agr assistant" APP—click "Please connect the device"—click "H12/MK15"—click "OK"—click "Execute work "—Click on the upper right corner "..."—Click on the square icon— Click on the obstacle avoidance radar — Click on "Read" — Click on "Enable the obstacle avoidance function" —Adjust the obstacle avoidance sensitivity to 1—Work mode automatically enable obstacle avoidance - select "hover" for obstacle avoidance behavior - set the obstacle avoidance safety distance to "6-8" - click "Hold".

10.Training on loss of control protection settings

Turn on the remote control—power on the drone, put it in a horizontal position and keep still— open the "Agr assistant" APP—click "Please connect the device"—click "H12/MK15"—click "OK"—click. "Execute work "—Click "... " in the upper right corner—Click the remote-control icon—Click "Read"—Explanation: Fail safe—Click "Hold".

11.Training on parameter setting explanation in the spray setting

Turn on the remote control—power on the drone, put it in a horizontal position and keep still— open the "Agr assistant" APP—click "Please connect the device"—click "H12/MK15"—click "OK"—click "Execute work " — Click on the upper right corner "... " — Click on the drone icon



—Click on "Spray Settings"—Click on "Read"—Explain: 1. Behavior of pesticide off protection; 2. Type of flowmeter; 3. Liquid level meter type; 4. Work mode; 5. Automatic pump control in work mode; 6. Calibration of flowmeter. — Click "Hold".

12.Explanation and training of maximum flight speed, return altitude, course speed, work completion behavior, U-turn, and nose orientation while return

12.1. Turn on the remote control—power on the drone, put it in a horizontal position and keep still—open the "Agr assistant" APP—click "Please connect the device"—click "H12/MK15"—click "OK"—click "execute operation"—Click on the upper right corner "..."—Click on the drone icon—Click on "Flight Parameters"— Click on "Read"— Explanation: 1. Maximum flight speed; 2. Return altitude; 3. Course speed; 4. Work completion behavior; 5. U-turn on; 6. Nose orientation when returning—Click "Hold".

12.2. Explanation and training on battery primary alarm, secondary alarm voltage setting

Turn on the remote control—power on the drone, put it in a horizontal position and keep still—open the "Agr assistant" APP—click "Please connect the device"—click "H12/MK15"—click "OK"—click "execute work"—Click "... " in the upper right corner—Click the drone icon—Click "Battery Settings"—Click "Read"— 12S battery primary alarm voltage is recommended to be set to 44.4V, and secondary alarm voltage is recommended to be set to 43.5 V, 14S battery primary alarm voltage is recommended to be set to 51.8V, secondary alarm voltage is recommended to be set to 50.4V, — click "Hold".

12.3. How to manually take over operation training after out-of-control protection, pesticide off protection, and work completion behavior execution

When the drone is performing automatic flight operations, if there are behaviors such as out-of-control return, pesticide off return, and return after the work is completed, if you want to manually take over the drone, turn the toggle switch on the upper left corner of the remote control — GPS/attitude/manual switch—Toggle back and forth once to realize manual takeover.



13. Flight operation procedures and precautions

Download software and real-name authentication steps:

Take out the mobile phone with Android system—find the software manager—scan the QR code of the "Agr assistant" APP—download and install the "Agr assistant" APP, open the "Agr assistant" APP—select "Register"—enter the mobile phone number, verification code, enter the password to be set—click "Confirm"—re-enter the mobile phone number, login password—click "Confirm"—select "My" in the lower right corner—Choose "Real Name Authentication"—Enter real name and ID number—Upload ID photo—Upload a hand-held ID photo — Click "Submit" — Wait for approval (note: it can only be used after approval)

Calibration of GPS:

Turn on the remote control (short press for 1 second, then long press the power switch for 3 seconds to turn on the remote control)—power on the drone, put it in a horizontal position and stay still—click to enter the "Agr assistant" APP—click "Execute Work"—click the three dots in the upper right corner—click the drone icon — click "Magnetic Compass Calibration"— click "Start Calibration" —at this time the LED indicator light of the drone is steady yellow, and two people lift up the drone, take the center of the drone as the center, rotate 3 times horizontally, until the LED indicator light turns blue—two people lift the drone, take the center of the drone as the center, turn the nose down, and rotate 3 times vertically, until the LED indicator light turns blue and flashes—the GPS calibration is successful at this time—the drone is powered off—and then powered on again.

Pre-flight preparations:

Turn on the remote control (short press for 1 second, then long press the power switch for 3 seconds to turn on the remote control)—Check the power of the remote control—Connect the remote control to the mobile phone with the USB data cable that comes with the remote control box—Take out the fully charged battery—Put the battery into the battery compartment and fix it tightly with straps—Power on the drone and place it in a horizontal position—Turn on the phone settings—Other settings—Turn on OTG—Turn on "Agr assistant" APP—click "Please connect the device"—Select Bluetooth, click "OK"—click "Execute Work"—click "..." in the upper right

Based in New York City & Toronto, GAO Tek Inc. is ranked as one of the top 10 global B2B technology suppliers. GAO ships overnight within the U.S. & Canada & provides top-notch support thanks to its 4 decades of experience.



corner of the operation page - select the bottom "..."—find "Remote Control Type" - select "T12"—Click the "X" in the upper right corner to close the page—Reopen the "Agr assistant" APP — Click "Please connect the device"— Select Bluetooth— Click "OK" —Click "Execute Work"— The upper left corner of the mobile phone displays green, and it prompts that it can takeoff normally—Check the number of GPS satellites (above 12)—check that the LED light must be green—the operator stands at a position 8 meters away from the tail of the drone - perform a Combination Stick Command(CSC) to unlock the motor—Take off: push the throttle up with the left hand, the drone will fly up—Landing: pull the throttle down with the left hand, the drone will fly down;—Flight: press the joystick with the left hand, the drone will rotate left on the spot; press the joystick with the left hand to the right, the drone rotates right on the spot;—Push the joystick up with the right hand, and the drone flies forward; pull down the joystick with the right hand, the drone flies backward; the drone tilts to the right and flies sideways—hover: when the left and right joysticks do not move, the drone hovers on the spot.

14.Explanation and training of voltage setting of battery primary alarm and secondary alarm

Turn on the remote control—power on the drone, put it in a horizontal position and keep still—open the "Agr assistant"—click "Please connect the device"—click "H12/MK15"—click "OK"—click "Execute work"—Click on the upper right corner "..."—Click on the drone icon—Click on "Battery Settings"—Click on "Read".

For 12S batteries, the first level alarm voltage is recommended to be set to 44.4V, and the second level alarm voltage is recommended to be set to 43.5V.

For 14S batteries, the first-level alarm voltage is recommended to be set to 51.8V, and the second-level alarm voltage is recommended to be set to 50.4V.

Note: There is a risk of crash when flying below the level 2 alarm voltage.



15. How to manually take over operation after out-of-control protection, pesticide off protection, and work completion execution

When the drone is performing automatic flight operations, if there are behaviors such as out-of-control return, pesticide off return, and return after work is completed, if you want to manually take over the drone, turn the toggle switch on the upper left corner of the remote control—GPS/attitude/manual switch—toggle once to realize manual takeover.

16. Safe flight precautions

16.1. The drone must be far away from the crowd when flying. It is strictly prohibited to fly over the crowd.

16.2. Operators and spectators are strictly prohibited from operating the drone within 6 meters of the drone.

16.3. It is strictly forbidden for operators and spectators to stand on the downwind of the drone.

16.4. It is strictly forbidden to fly in non-open places or areas with dense obstacles, and the trainers are obliged to ensure the personal and property safety of the surrounding people.

16.5. It is strictly forbidden to fly under conditions such as fog, smog, and sandstorms that obstruct the line of sight.

16.6. It is strictly forbidden to fly in wind of level 4 and above.

16.7. It is strictly forbidden to display the automatic return function in places with dense obstacles.

16.8. It is strictly prohibited for the drone to fly out of the line of sight of the operator. Always keep the drone within the line of sight of the operator.

16.9. It is strictly forbidden to use autonomous flight in the case of obstacles and dense environments.



16.10. It is strictly forbidden to use the autonomous take-off operation function in the case of dense obstacles at the take-off point.

16.11. It is strictly forbidden to use the human body as an obstacle avoidance object to demonstrate the obstacle avoidance function.

16.12. It is strictly forbidden to let the drone's propeller be lower than the obstacle when testing the obstacle avoidance function.

16.13 It is strictly prohibited to choose far away obstacles as obstacle avoidance objects when testing obstacle avoidance function. Choose closer obstacle avoidance objects, which should not exceed 50 meters, and the line of sight is controllable. When testing the obstacle avoidance function, if the drone is 6 meters away from the obstacle and does not avoid the obstacle, it should be pulled high in time to prevent a crash or the propeller hitting the obstacle. When testing the drone flying around the obstacle, the radius of the obstacle should not be less than 6 meters of the actual radius of the obstacle.

16.14. It is strictly forbidden to start the motor when the propeller is folded.

16.15. It is forbidden to operate drones without pipe air exhaust on the ground.

16.16. Check whether the obstacle avoidance radar is on and whether the obstacle avoidance radar can avoid obstacles.

16.17. Test flights over water are strictly prohibited.

16.18. Check that the GPS arrow is pointing directly in front of the drone.

16.19. It is strictly forbidden for the drone to take off with the nose facing the operator.

16.20. Check whether the battery power is sufficient, whether it meets the flight requirements, whether the primary and secondary alarm voltages are set correctly.

16.21. Check if the drone needs to calibrate GPS.

16.22. Check the voltage range supported by the drone before powering on the drone.

Based in New York City & Toronto, GAO Tek Inc. is ranked as one of the top 10 global B2B technology suppliers. GAO ships overnight within the U.S. & Canada & provides top-notch support thanks to its 4 decades of experience.



16.23. It is strictly forbidden to fly the drone with a full load when the battery is dead or low.

16.24. If the drone only supports 6S batteries, a warning sign must be posted when assembling the drone. If the warning sign is not posted, resulting in wrong connection of the battery and damage to the electronic equipment, the assembler shall bear responsibility.

16.25. When the drone is operating, there must be no people in the flight path of the drone. If there are people in the path, the drone needs to fly around.

16.26. It is strictly forbidden to fly near the airport or over the city.

16.27. It is strictly forbidden to fly near high-voltage lines and high-speed rails.

16.28. It is strictly forbidden to fly on the side of the road, in the community, or in places where there are crowds or vehicles.

17. Safe operation precautions

17.1 Avoid causing harm to crops or surrounding crops and causing poisoning to cultured animals

1) Obstacle survey in the work area: During field planning, carefully observe the internal and edge obstacles, measure the obstacles, and avoid collisions between agricultural drones and obstacles.

2) Surrounding planting conditions: Before operation, observe the planting conditions of surrounding crops to see if there are sensitive plants, to avoid floating operation accidents, and to work only after confirming safety, so as to avoid economic losses.

3) Observe the surrounding breeding conditions: if there are breeding conditions around the operation area, there may be the possibility of poisoning and death of the breeding animals.

4) Before operation, it should be confirmed whether there are bees and beekeepers in the operation area. If there are a large number of bees in the operation area, the operation plan and operation time should be negotiated with farmers and beekeepers to avoid bee poisoning and death.

17.2 Avoid personnel poisoning and injury



- 1) Avoid pesticide poisoning of operators: Refuse to use highly toxic pesticides, which will effectively avoid pesticide poisoning incidents.
- 2) Wear appropriate protective equipment during the dispensing process, including masks, glasses, and nitrile gloves; avoid being in the upwind direction of the pesticide tank.
- 3) Pesticide is poured slowly to avoid splashing.
- 4) After dispensing, hands must be washed thoroughly before touching other parts of the body.
- 5) During the operation, pay attention to self-protection, work in the upwind direction, and keep a safe distance of more than 6 meters from the agricultural drone to avoid being splashed by pesticides. It is forbidden to enter the operation area after the operation is completed to avoid inhalation poisoning.

17.3 Avoid injury accidents and ensure personnel safety

In order to avoid being harmed by agricultural drones, you should pay attention to:

- 1) Keep a safe distance of more than 6 meters from the agricultural drone at all times.
- 2) In the event of an accident, it is absolutely forbidden to grasp any part of the agricultural drone to avoid being injured.
- 3) Prohibit head-to-head takeoff.
- 4) It is strictly forbidden for the agricultural drone operators and drivers to work at full load all day without rest at noon, and to work continuously overnight, resulting in poor mental state, fatigue driving, and easy to cause drone crashes or vehicle traffic accidents.
- 5) It is forbidden to take off and land on roads with a large flow of people to avoid collisions with pedestrians and vehicles.
- 6) It is forbidden to take off in the square to avoid collision with the surrounding onlookers.



- 7) It is forbidden for the operator not to stand behind the drone to take off, so as to avoid the operation error of the operator, and the agricultural drone will fly in the wrong direction, causing the agricultural drone to collide with the ground crew.
- 8) Strengthen the training of the cooperation between agricultural drone operators and ground crews, so as to avoid the uncoordinated cooperation between the operator and the ground crew, resulting in the impact of the drone.
- 9) Empty irrelevant personnel in the operation area in advance before the operation. If you find that there are people in the operation area, you should stop the operation immediately. If you find that you are about to hit, you can avoid the impact by raising the height, rolling and pitching the joystick. Perform a Combination Stick Command (CSC) or reverse of the lever quickly locks the throttle and reduces the degree of impact damage.

17.4 Avoid equipment loss caused by various reasons

Strengthen drone operation training for operators to avoid unnecessary losses.

- 1) Strengthen the operator's understanding of concepts related to calibration points and correction of deviations to avoid route deviations.
- 2) Strengthen the learning of AB point operation to avoid the wrong order of AB point or wrong understanding of direction when AB point is operated, causing the agricultural drone to move laterally and hit obstacles.
- 3) Strengthen the familiarity with the one-key return function, and avoid blind use of the one-key return function due to unfamiliarity, resulting in equipment loss.
- 4) Regularly maintain and replace the connecting plug to avoid heating or melting of the plug.
- 5) Avoid high temperature conditions, including sun exposure or direct use of the battery without cooling after use, which will reduce the life of the battery or charger.
- 6) The spraying system was not cleaned after spraying, resulting in pipelines or pumps being corroded by pesticide residues for a long time.

Based in New York City & Toronto, GAO Tek Inc. is ranked as one of the top 10 global B2B technology suppliers. GAO ships overnight within the U.S. & Canada & provides top-notch support thanks to its 4 decades of experience.



7) Before taking off, the screws of all parts of the agricultural drone should be checked to avoid the screws falling off and causing the crash of the drone.

17.5 Safety precautions for night operation

Agricultural operations at night should be prepared in advance to avoid safety accidents:

- 1) Prepare night lights to facilitate take-off and landing, replace batteries and medicine boxes, and avoid collisions or personal injuries caused by poor vision at night.
- 2) Equipped with at least 5 sets of batteries or more to avoid insufficient battery protection due to few batteries or damage to the battery or battery fire due to high temperature charging.
- 3) Equipped with a generator of 5000W or above to avoid damage to equipment due to insufficient power of the generator.
- 4) Survey the operation area in advance and plan the route well.
- 5) Operators should wear long clothes, long trousers and stockings, and carry floral water and mosquito repellent water to avoid exposing the skin and causing mosquito bites.
- 6) It is mandatory to carry a flashlight or headlamp for walking at night.
- 7) Wear water boots to avoid getting water on your feet and stepping on poisonous snakes.
- 8) Driving at night, avoid fatigue driving and speeding.
- 9) Clear the work area before the operation to avoid serious injury caused by the collision between the agricultural drone and the ground personnel.
- 10) When taking off and landing, the agricultural drone should keep a safe distance of more than 8 meters from ground personnel.
- 11) In night operation, it is necessary to turn on the lighting of agricultural drone and pay attention to the FPV picture at all times to obtain the real-time picture in front of it to ensure flight safety.



12) When replacing the battery, make sure the battery is fixed and the battery is fully charged. 13) When planning a route during the day, it is necessary to determine in advance whether there are obstacles between the takeoff and landing point of the agricultural drone and the starting point of the operation. If there are wires above the takeoff and landing point, set the takeoff altitude in advance to avoid collision with the wires. Or manually unlock and take off to the starting point of the execution route, and then execute the operation when reaching the take-off point.

14) During operation, real-time detection of the drone status and accurate position is performed through the FPV camera screen and the position displayed on the remote-control screen of the agricultural drone, and then the Google satellite map is used to assist in judging whether there are obstacles at the border of the field. For areas with obvious obstacles, it is necessary to be vigilant.

15) Pull the agricultural drone back on the field in advance to add pesticide through the prompt of the pesticide break point of the remote control or the judgment of the remaining dose, so as to avoid the agricultural drone hovering in the middle of the field without pesticide.

16) Manually control the agricultural drone to return to the take-off point through the trajectory of the already operated route, pay attention to the height change, and use one-key return operation. The return trajectory is in a straight line from the pesticide break point to the return point, ensuring that there are no obstacles and no wires in the middle of the return point, if the field is too small when landing, you need to use manual landing.

17.6 Pay attention to safe operation in high temperature environment

1) In order to ensure the operation effect and the comfort of the personnel, try to choose morning and evening hours for operation. In areas with large plots, fewer obstacles, and relatively few mosquitoes and snakes, you can choose evening operations. Not only the operation effect is better, but also can avoid being in high temperature environment.

2) Wear breathable sun protection clothing, hats, or ice sleeves to minimize exposed skin, and try to work in the shade of trees. If there is no shade, consider holding an umbrella.



3) When working in a high-temperature environment, you should pay attention to keeping drinking water. Keep a small amount of water for multiple times, preferably 200ml each time, at the same time, try to choose light salt water, in order to subsidize electrolytes, avoid the body lack of electrolytes and heat exhaustion.

17.7 Abide by laws and regulations

1) **Real-name authentication:** Real-name registration of drone shall be carried out in strict accordance with the requirements of the Real-name Registration and Management System of Civil Unmanned Aircraft issued by the Civil Aviation Administration of China.

2). **It is strictly forbidden to fly in the no-fly zone**

The following key areas are no-fly areas: 1. Party and government offices; 2. The clearance protection area of the civil airport along the center line of the runway 10 km on each side and 20 km outside the runway end; 3. Key target areas for the prevention and control of military industry, communications, water supply, power supply, energy supply, storage of dangerous chemicals, and storage of large materials

4. Stations, docks, ports, commercial districts, streets, parks, large-scale event venues, exhibition halls, schools, hospitals and other densely populated areas ;

5. Temporary control areas announced by the people's governments of cities, districts and counties (autonomous counties).

These behaviors are not allowed:

1. Secretly photographing military installations, important party and government offices, and other confidential places;

2. Disturbing the order of work, production, teaching, scientific research and medical treatment of government organs, organizations, enterprises and institutions;

3. Obstructing the staff of state organs to perform their duties in accordance with the law;

4. Chasing, intercepting, or making noise that interferes with the normal life of others;

Based in New York City & Toronto, GAO Tek Inc. is ranked as one of the top 10 global B2B technology suppliers. GAO ships overnight within the U.S. & Canada & provides top-notch support thanks to its 4 decades of experience.



- 5. Throwing, dumping objects on injuring others, damaging public or private property; 6. Peeping, secretly photographing personal privacy;
 - 7. Other behaviors that violate laws and regulations.
- 3) If the operation is done in different places, the relevant registration formalities need to be done in the local public security organ.
- 4) Apply for flight routes in advance and make flight reports before flying.
- 5) Strictly abide by relevant national laws and regulations

18. List of dangers and hazards and solutions

Item		Problem Description	Solutions
1	Toggle the stick in a hurry	This is one of the most common reasons for drone crash, because not to master all the functions of the drone, toggle the stick in a hurry while meeting special circumstances. Eventually the drone crashed in a collision.	When all devices are not damaged and the power is sufficient, check mobile devices, remote controls, drone and other devices before takeoff to keep the power sufficient.
2	Fly when the battery is low	Please return as soon as possible when the remote control sends a low power warning, otherwise the drone cannot return or is lost due to lack of power.	Please return as soon as possible when the remote control sends a low power warning to ensure safe return of the drone.
3	Complex environment flight	When flying in complex environments such as buildings and signal towers, the drone will	Observe the surrounding environment before flying, and choose an open place



		be affected by interference, which will affect the control and easily cause the drone to collide and crash.	without tall buildings around as the flying place. And make sure the flight site is outside the restricted flight area.
4	Private modification	Modifying the drone or remote controller privately, or using accessories from other manufacturers, may cause the drone to lose control and crash	If you need to install accessories, please use original accessories.
5	GPS satellite signal is poor	If the satellite signal is poor and the environment does not meet the drone's down-looking positioning requirements, the drone's propellers will be in a drifting state. Improper operation may result in collision and crash.	Make sure the GPS signal of the drone is good. It is recommended to search for more than 10 stars and the GPS signal is greater than or equal to 4 grids before flying. (More than 10 stars and GPS signal greater than or equal to 16 are excellent)
6	Flying out of visual range	When flying outside the visual range, the pilot can not accurately judge the attitude of the drone, and may mistakenly toggle the stick, resulting in the crash of the drone.	When flying, please control the drone with insight and keep away from buildings, obstacles, crowds, water surfaces, etc.



7	Image transmission signal loss	When the image transmission signal is lost, the pilot can not see the real-time flight picture and toggle a wrong stick, resulting in a collision and crash	If you find that the image transmission signal is lost at the first time, don't panic, don't toggle the stick indiscriminately, and return flight as soon as possible. If the drone is out of sight, please press one-key return.
8	Flying in bad weather	Bad weather such as strong wind and rainstorm will affect the flight stability or damage the performance of the drone, and eventually lead to crash of the drone	Please do not use the drone in bad weather such as strong wind and heavy rain. If the drone meets strong wind and heavy rain during flight, please return as soon as possible.
9	Flying close to water	Due to the inability to identify the water surface, the drone is prone to drift and fall when flying close to the water surface, causing the drone to crash during flight.	If the drone encounters lakes, rivers, or creeks during flight, please leave as soon as possible to sure flight safety.
10	Failure to meet obstacle avoidance condition	When the surrounding environment does not meet the conditions for visual obstacle avoidance, the drone will not be able to avoid obstacles in time,	When the surrounding terrain is complex and there are many obstacles, reserve a safe distance of 10-15 meters between the drone and obstacles



		which may eventually cause the drone to collide and crash.	(according to the actual reservation) to ensure flight safety
11	Fast landing	Quickly pushing down the control stick when landing will cause the drone to lose weight, and the ground will be uneven and the drone will fall.	When landing, the joystick should be pushed down slightly, and the drone will keep descending at a uniform speed until it touches the ground, and the motor will stop working when the joystick is down for 3-5seconds. (After landing, be sure to turn off the drone firsthand then turn off the remote control to ensure safety)
12	Abnormality of propeller and motor	Abnormal propeller and motor will cause the drone to crash out of control during flight	Before take-off, check whether the rotation of the motor and the propeller are consistent, to ensure that the propeller is installed correctly and the motor can start normally. The propellers are not damaged, and no foreign matter in the motor



13	Compass calibration failure	Failure to calibrate the compass will cause the drone to circle in place, causing loss of control and damage to the drone	To ensure your safe flight, it is recommended to calibrate the compass before each flight. Please keep away from strong magnetic fields or near large metal objects during calibration, such as magnetic mines, parking lots, and building areas with underground steel bars.
14	The power plug of the drone is black and abnormally hot	If the drone's power supply plug turns black and becomes abnormally hot, it will cause the drone to lose power, short-circuit out of control and crash during flight.	The power supply plug of the drone should be replaced regularly. If the plug is found to be black and abnormally hot, it should be replaced in time to ensure the normal power supply
Local laws and regulations should be strictly observed during flight to ensure flight safety. (Article 17of the manual, Safety operation precautions Article 7			
Read the manual carefully before taking off			

19.Installation troubleshooting

Drone LED indication troubleshooting

Based in New York City & Toronto, GAO Tek Inc. is ranked as one of the top 10 global B2B technology suppliers. GAO ships overnight within the U.S. & Canada & provides top-notch support thanks to its 4 decades of experience.



LED Indicator	Problem Description	Solutions
Red, green and yellow flashing continuously	Power-on self-check function	Normal
Green light flashing slowly	GPS intelligent operation mode	Flight indicator in full autonomous mode
Low voltage alarm	Low voltage alarm	The yellow light indicates low battery, land immediately
Yellow light flashing quickly	Serious low power alarm	When the drone starts to descend slowly, push the throttle to control the drone to find a safe place to land
Yellow light flashing slowly	Attitude mode	In this mode, the drone may be interfered, and then the drone will automatically switch to the attitude mode. In the attitude mode, there is no fixed-point function for flight, so it is necessary to manually correct the drone fixed-point
White light	Drone out of control	It is necessary to control the drone as much as possible and choose a safe place to land.

Based in New York City & Toronto, GAO Tek Inc. is ranked as one of the top 10 global B2B technology suppliers. GAO ships overnight within the U.S. & Canada & provides top-notch support thanks to its 4 decades of experience.



The green light flashes quickly when taking off	The return point position is successfully recorded	Normal
Yellow light flashing quickly	Remote control signal interruption	The drone will return to the take-off point after losing control
The red-light flashes quickly (appears when the stick is toggled)	The IMU deviation is too large or the IMU is being initialized	Check whether the main control is loose
The red and yellow lights flash alternately	Compass data error	Re-calibrate needle compass

20.Package and transport

Shipped in carton, the built-in foam card slot can firmly fix the agricultural drone. The outer box is printed with light handling, fragile care, no pressure and upward arrow (no handstand), which can effectively ensure that the agricultural drone will cause damage to the drone during transportation. It can be transported according to the position shown in the packing box by common means of transportation, but mechanical collision and direct rain and snow should be avoided.

21.Cleaning and maintenance requirements

The drone spraying system must be cleaned with clean water 3-5 times a day after operation. Due to the strong corrosion of pesticides, the service life of the aging liquid pump of the pesticide pipe will be short and the nozzle will be blocked.



Note: The maintenance shall be carried out by the authorized maintenance company. The maintenance record shall be filled in and stamped, otherwise the maintenance record will be invalid. Welcome to use the company's products, we will provide you with satisfactory service, if there is a product quality problem, please contact the seller.